

Job _____
Item# _____

Platinum Series

- SSB-32 84,000 BTU NAT (74,000 BTU LP)
- SSB-36 84,000 BTU NAT (74,000 BTU LP)
- SSB-45 126,000 BTU NAT (111,000 BTU LP)

Standard Features

- Standard (2) years limited parts and labor warranty (reference <http://www.southbendnc.com/service.html> for limited warranty details).
- Stainless steel cradle and carriage construction.
- Stainless steel front, sides and back.
- Patent pending rack adjust mechanism, nine positions with paddle release.
- Removable 2-1/2 quart griddle grease catch.
- Removable 7-3/4 quart broiler grease drawer.
- 1/2" thick quick recovery searing griddle (heated with broiler flue gas).
- 4" griddle splash guards.
- Independent variable adjust burner control valves.
- Smooth track dura-glide meat rack with concealed roller bearings.
- Cool temp handle, knobs and controls.
- Chrome plated cooking grids.
- Mounting options include equipment stand (standard), countertop, cabinet base, refrigerated or freezer base.
- 1-1/4" front manifold with 1" rear gas supply connection.
- 6" adjustable legs or 6" adjustable caster (except counter top model).



SSB-45 shown on standard equipment stand with optional casters.

STANDARD CONSTRUCTION SPECIFICATIONS

Exterior Finish: Front, sides, rear and exterior bottom constructed of #3 polished 430 and 304 stainless steel.

Range: Radiant Steakhouse Broiler with Griddle Top, 32", 36" and 45" -wide front-manifold sectional range with 84K BTU NAT(74K BTU LP) for 32" and 36" models, 126K BTU NAT(111K BTU LP) for 45" model.

Front Rail: 9-1/4" front rail.

Battery: Unit can be in any position in a battery. If the unit is at the end of the battery, the end side will be solid (rather than have a cover plate over the end of the front manifold).

Equipment Stand: Stainless steel, 27-1/2" high, open shelf stand with adjustable legs (casters optional).



Models: SSB-32 SSB-36 SSB-45

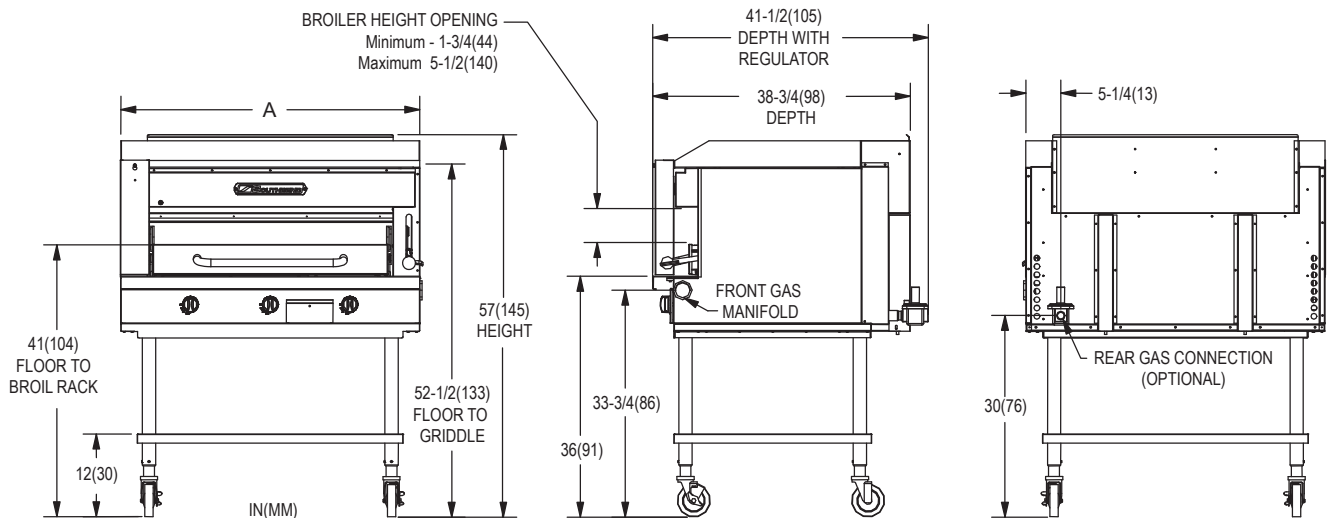

Note: Dimensions not shown on Counter Top model same as above.

MODEL	"A" WIDTH	BROILER WEIGHT LB(KG)	STAND WEIGHT LB(KG)	BROIL OPENING WIDTH	BURNER QTY	BTUs		Griddle Plate Size			Broiler Grid Size			Weight	Crate Size
						Nat BTU	Lp BTU	WIDTH	DEPTH	AREA IN ² (M ²)	WIDTH	DEPTH	AREA IN ² (M ²)		
SSB-32	32 (813)	385 (175)	45 (20)	21 (533)	2	84,000	74,000	27-3/4 (705)	28 (711)	777 (.501)	20-1/4 (514)	26-1/2 (673)	537 (.346)	429 lbs. (195 kg)	58"x48"x69"
SSB-36	36 (914)	460 (209)	52 (24)	25 (635)	2	84,000	74,000	31-3/4 (806)	28 (711)	889 (.574)	24-1/4 (616)	26-1/2 (673)	643 (.414)	665 lbs. (302 kg)	58"x48"x69"
SSB-45	45 (1143)	550 (249)	67 (30)	34 (864)	3	126,000	111,000	40-3/4 (1035)	28 (711)	1141 (.719)	33-1/4 (845)	26-1/2 (673)	881 (.569)	831 lbs. (377 kg)	58"x48"x69"

UTILITY INFORMATION

MODEL	GAS (BTU/HOUR)	
	NATURAL	PROPANE
SSB-32	84,000	74,000
SSB-36	84,000	74,000
SSB-45	126,000	111,000

GAS: Each unit has a 1-1/4" front manifold that couples to the adjacent sectional unit(s), and a 1" rear gas connection with a male NPT connector. Minimum gas supply pressure is 7" W.C. for natural gas and 11" W.C. for propane. All sectional units require a regulated gas supply (a pressure regulator must be ordered separately). If using a flexible-hose gas connection, the inside diameter of the hose must not be smaller than the connector on the unit and must comply with ANSI Z21.69, providing an adequate means of restraint to prevent undue strain on the gas connection.

MISCELLANEOUS

- If casters are used with a flexible-hose gas connection, a restraining device should be used to prevent undue strain on the hose.
- Minimum clearance from noncombustible construction is 0". Installation next to combustible construction is not recommended.
- Installation under a vented hood is recommended.
- Check local codes for fire and sanitary regulations.

NOTICE:

Southbend has a policy of continuous product research and improvement. We reserve the right to change specifications and product design without notice. Such revisions do not entitle the buyer to corresponding changes, improvements, additions or replacements for previously purchased equipment.

OPTIONS and ACCESSORIES

- External pressure regulator
- Casters on equipment stand (front two casters lock)
- Front rail options:
 - cutouts in front rail for sauce pans
 - Cable restraint kit (to restrict movement when on casters)
 - 7-1/4" front rail (to match old style sectional)
 - Removable shelf inside cabinet
 - square belly bar mounted on 7-1/4" front rail

**INTENDED FOR COMMERCIAL USE ONLY.
NOT FOR HOUSEHOLD USE.**



1100 Old Honeycutt Road, Fuquay-Varina, NC 27526
(919) 762-1000 www.southbendnc.com