



Model SG14RS with Options Tube Fired Gas Fryer



Model SG14RS w/Options

Project _____

Item number _____

Quantity _____

STANDARD ACCESSORIES

- Choice of basket options
 - Two nickel-plated, oblong, wire mesh baskets
 - One nickel-plated, square, wire mesh basket
- One nickel-plated tube rack
- One drain extension
- One drain line clean-out rod
- Fryer cleaner sample
- Rear gas connection
- Manual gas shutoff
- 1 1/4" (3.2 cm) full port drain valve
- Built-in integrated flue deflector
- Removable basket hanger for easy cleaning
- 9" (22.9 cm) adjustable legs
- Cabinet - stainless steel front, door, and sides
- Tank - stainless steel

AVAILABLE OPTIONS & ACCESSORIES

- Stainless steel back
- Basket lift*
- Solid state thermostat**
- Digital controller**
- Triple Baskets
- Covers
- Intellifry computer control**
- Computer back-up thermostat
- 9" (22.9 cm) adjustable legs

* Only available with digital or computer controls.
 **Includes matchless ignition, melt cycle, and drain valve interlock switch.

STANDARD SPECIFICATIONS

CONSTRUCTION

- Welded tank with an extra smooth peened finish ensures easy cleaning.
- Long-lasting, high-temperature alloy stainless steel heat baffles are mounted in the heat exchanger tubes to provide maximum heating and combustion efficiency.
- Standing pilot light design provides a ready flame when heat is required.
- Stainless steel front, door, side, and splashback.
- Heavy duty 3/16" (.48 cm) door hinge.

CONTROLS

- Millivolt thermostat maintains selected temperature automatically between 200°F (93°C) and 400°F (190°C-CE).
 - Integrated gas control valve acts as a manual and pilot valve, automatic pilot valve, gas filter, pressure regulator, and automatic main valve.
 - Gas control valve prevents gas flow to the main burner until pilot is established and shuts off all gas flow automatically if the pilot flame goes out.
 - Temperature limit switch safely shuts off all gas flow if the fryer temperature exceeds the upper limit.
 - New Solstice burner/baffle design.***
 - Increases cooking production.
 - Lowers flue temperature.
 - Improves working environment.
 - Generates more production per BTU.
- ***Compared to previous models.

OPERATIONS

- Front 1 1/4" (3.2 cm) full port drain for quick draining.
- 9" (22.9 cm) clearance allows for ease of cleaning.

APPROVALS

- CSA Certified (AGA, CGA)
- NSF Listed
- MEA Approved
- CE Certified
- Australian Gas Assoc. Certified (AuGA)



Patent Pending

Financing Available-Maytag Commercial Lease Program
Call 1-800-666-6812 for Details



Model SG14RS with Options - Tube Fired Gas Fryer

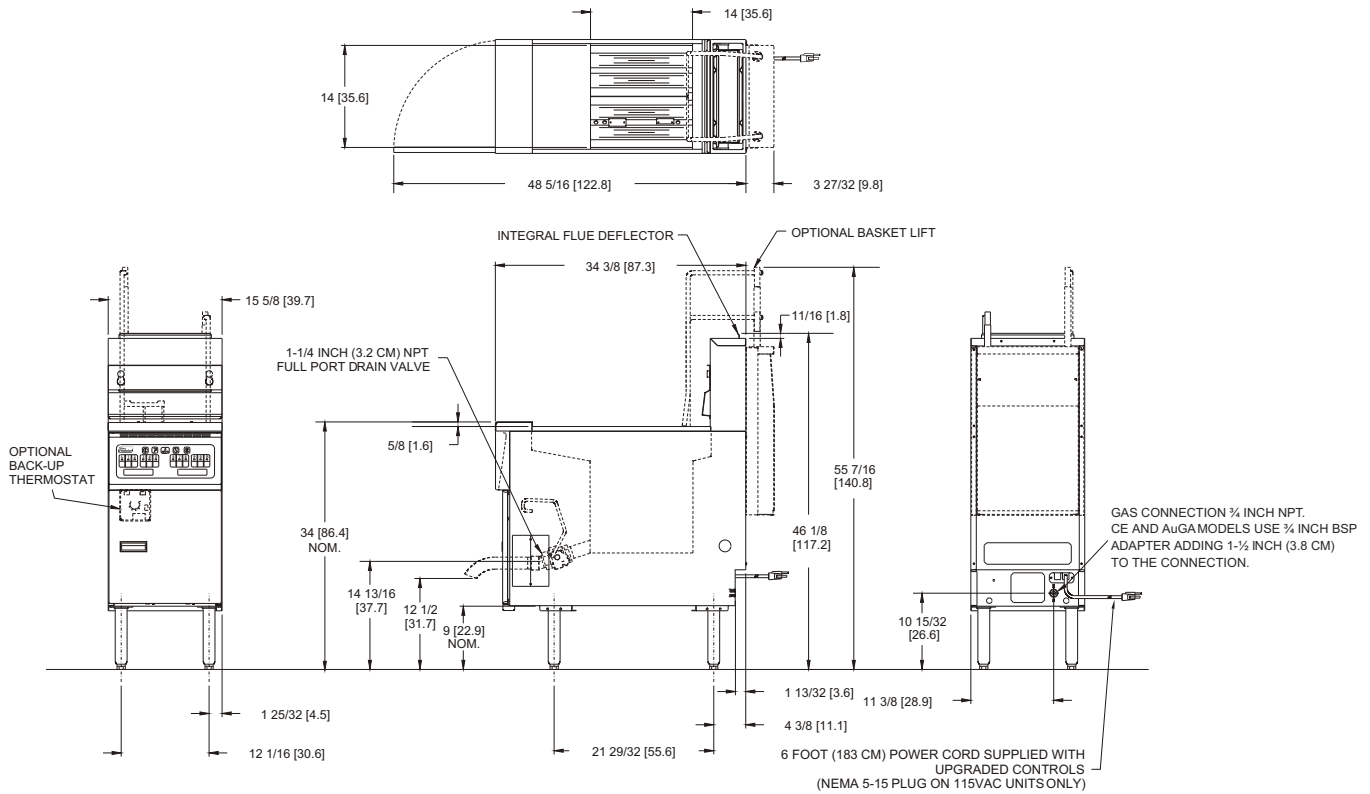

GAS REQUIREMENTS

Gas Input Per Hour			
122,000 BTUs / 36 kW (CE) / 129 megajoules (AuGA)			
Gas Type*	Recommended Minimum Store Manifold Pressure	Burner Manifold Pressure	*For other gas types, contact your Dealer/Distributor.
Natural Gas	7" W.C. / 17.4 mbars / 1.75 kPa	4" W.C. / 10 mbars / 1 kPa	Check plumbing/gas codes for proper gas supply line sizing.
L.P. Gas	13" W.C. / 32.4 mbars / 3.25 kPa	10" W.C. / 25 mbars / 2.5 kPa	
Clearance Information	Fryer Front	Fryer Sides, Rear, Bottom to any combustible material	Fryer Flue Area
All Models	30" (76.2 cm) min.	6" (15.2 cm) Do not Curb Mount	Do not block or restrict the flue gasses from flowing into the

ELECTRICAL

Control Type	Voltage / Phase / Frequency	Amps
Millivolt	Not required	0
Upgraded controls (solid state, digital, computer, basket lift)	115 / 1 / 60	1.7
	220-230-240 / 1 / 50	0.9
Upgraded controls options includes matchless ignition, melt cycle and drain valve interlock at no additional amps.		

OIL CAPACITY

40-50 pounds (18-23 kg)

PERFORMANCE CHARACTERISTICS

Cooks 110 lbs (50 kg) of fries per hour
Frying Area 14 x 14 x 4 in
(35.6 x 35.6 x 10.2 cm)

SHIPPING INFORMATION

Model	Shipping Weight	Shipping Cube	Shipping H x W x L
Single Millivolt	198 lbs 90 kg	19 ft ³ .54 m ³	45 1/4 x 18 3/4 x 38 1/2 in 114.9 x 47.6 x 97.8 cm
Single Upgraded Controls	208 lbs □ 94 kg	33 ft ³ .93 m ³	58 x 22 1/2 x 43 1/2 in 147.3 x 57.2 x 110.5 cm

□ Add 50 lbs (23 kg) for Basket Lifts

SHORT FORM SPECIFICATION

Provide Pitco Model SG14RS tube fired gas fryer. Fryer shall have an atmospheric burner system combined with four stainless steel heat tubes utilizing high temperature alloy stainless steel baffles. Fryer shall have a deep cool zone; minimum 16% of total oil capacity to trap burnt particles, crumbs and black specks. Fryer cooking area shall be 14" x 14" (35.6 cm x 35.6 cm) with a cooking depth of 4" (10.2 cm). Heat transfer area shall be a minimum of 838 square inches (5,406 sq. cm). Provide accessories as follows:

TYPICAL APPLICATION

Frying a wide variety of foods in a limited amount of space. Frying that requires a high volume production rate.