



PATENTS PENDING

Principle

Middleby Marshall PS Series conveyor ovens bake both faster and at a lower temperature than other ovens. Patented vertical columns of hot air move heat aerodynamically instead of using high temperatures. The streams of hot air remove the boundary layers of cool heavy air which tend to insulate the product. This gives very rapid baking without burning the product. All PS624 WOW![™] ovens are designed to cook product 30% faster than other conveyor ovens.

General Information

The PS624 conveyor oven is ideally suited for Kiosk and express-style locations where smaller ovens are required.

Standard Features

- Patented EMS Energy Management System reduces energy consumption and increases cooking efficiency
- Patented “High-h” convection heat transfer technology
- 24” (610mm) long cooking chamber with 18”(457.2mm) wide belt
- 52”(1321mm) long, 36”(914mm) deep, and 22.5”(572mm) high overall dimensions
- Furnished with 4”(102mm) legs.
- Stackable up to three high.
- Microprocessor-controlled bake time/conveyor speed
- Stainless steel front, sides, top and interior
- Reversible conveyor direction
- High speed conveyor (Range of 0:30 - 12:00)
- Automatic “energy eye” saves energy when no product is in the oven

Optional Features

- Stand with casters
- Exit shelf with stop
- Extended warranty available
- Split belt - two 9” (229mm) belts with individually adjustable speed settings

Energy Management System

The PS624 WOW![™] oven features an Energy Management System (EMS) that automatically reduces energy consumption.

Cleanability

PS624 Ovens are designed for easy cleaning. Removable parts include: crumb pans, end panels and air fingers.

Easily Serviced

Control compartment is designed for quick and easy access.

Warranty

All PS624 models have a one year parts and labor warranty. Oven start-up and demonstration are included at no additional charge (USA Only)

Ventilation

Use of a ventilation hood is not required for proper operation, but installation must conform with all local codes and regulations.

NOTE: Drawings show ovens equipped with casters.

PS624-1

TOP VIEW

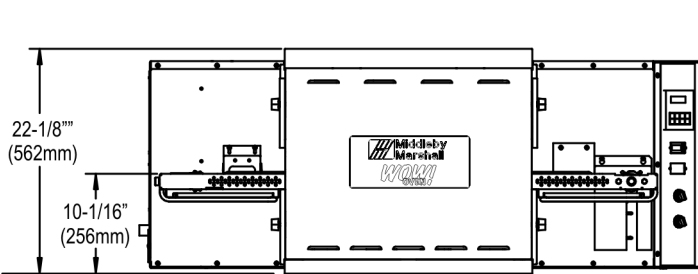
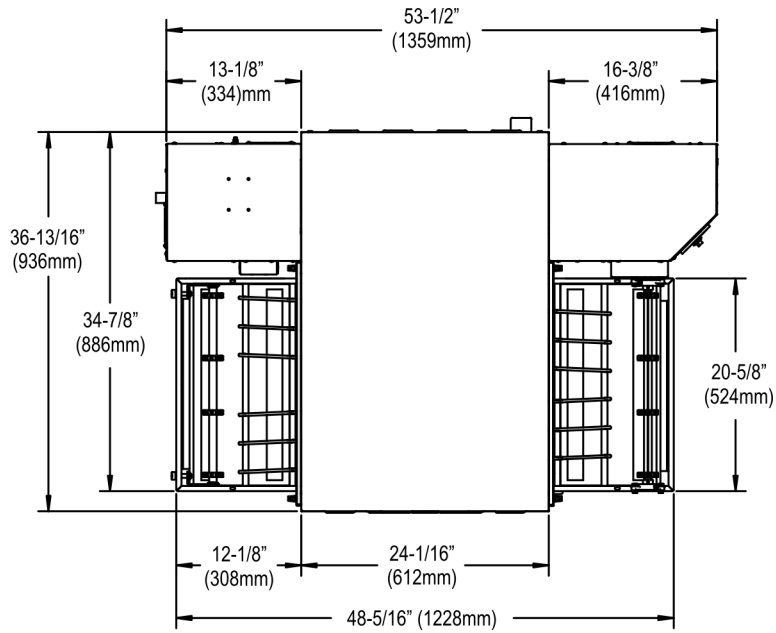

FRONT VIEW

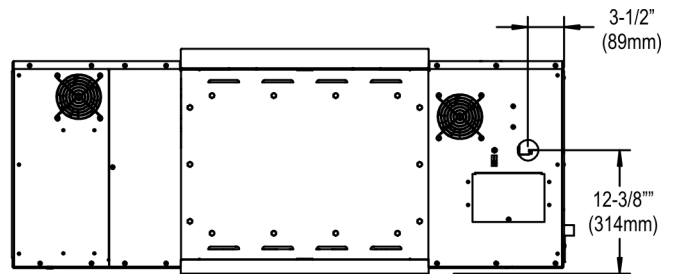

BACK VIEW

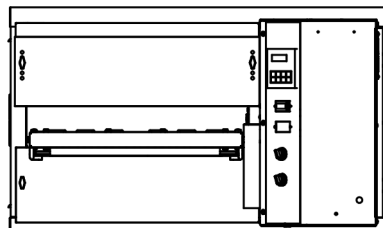

SIDE VIEW

NOTE: Drawings show ovens equipped with casters.

PS624-2

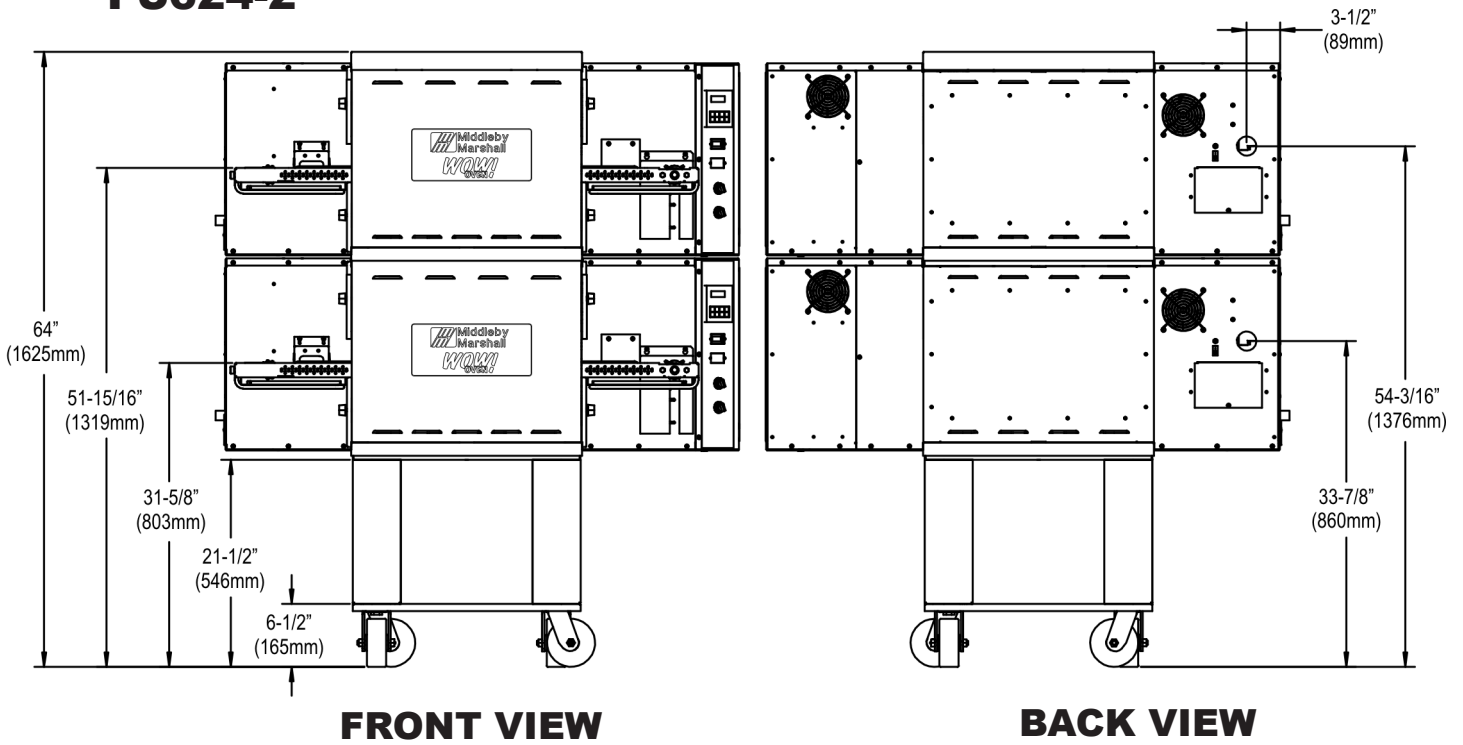

PS624-3

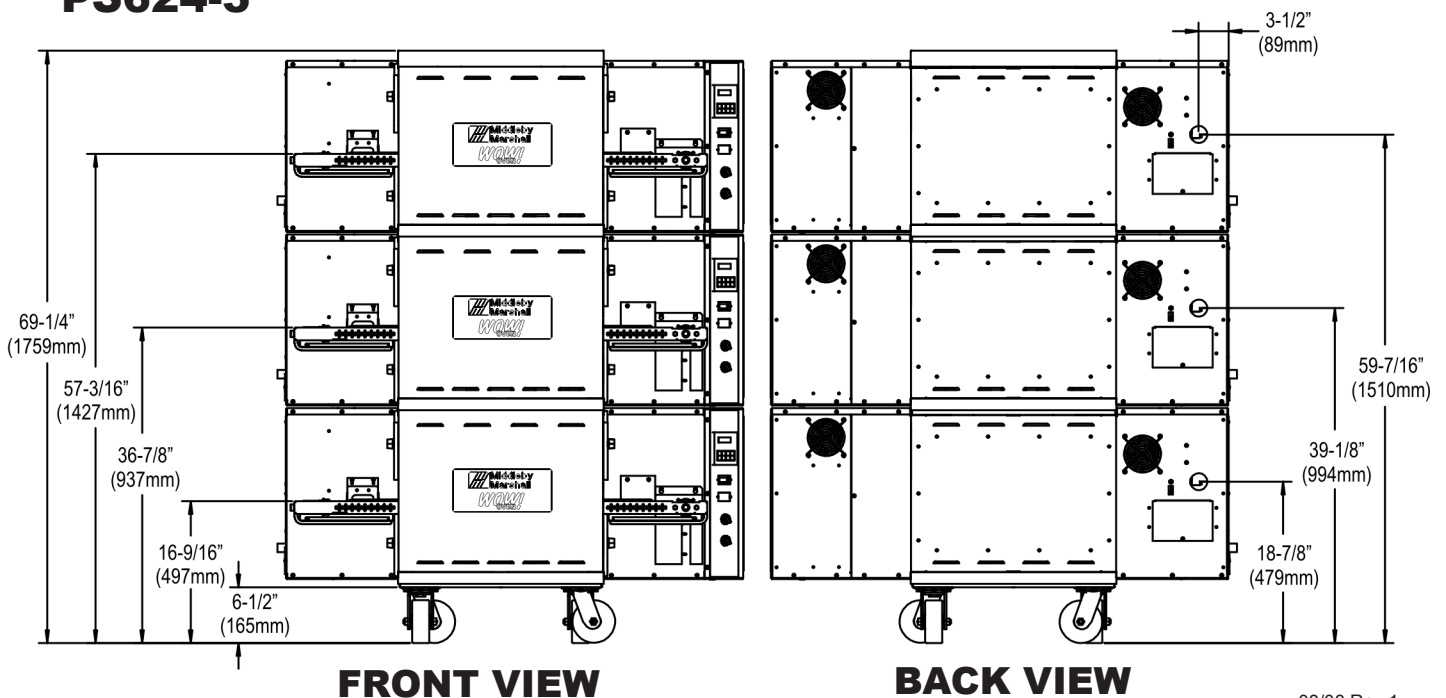

RECOMMENDED MINIMUM CLEARANCES

Rear of Oven to Wall	Control end of conveyor to wall	Non-control end of conveyor to wall
0"	0"	0"

GENERAL SPECIFICATIONS

	Heating Zone	Baking Area	Belt Length	Belt Width	Overall Length (12" exit trays installed)	Height	Depth	Maximum Operating Temp	Bake Time Range	Ship Wt	Ship Cube
PS624	24" 610mm	3.0 sq ft 0.28 sq m	48" 1219 mm	18" 457mm	64" max 626mm	22.5" 572mm	36" 914mm	600°F 316°C	00:30- 12:00 min	360 lbs 163.3 kg	61.1 ft3 1.73 m3

ELECTRICAL SPECIFICATIONS

Version	Voltage	Phase	Freq	K.W.	Supply	Breakers
DOMESTIC	208v	3	60 hz	14.4	3 pole, 4 wire (L1, L2, L3 & GRND)	50A Service
	480v	3	50/60 hz	14.4	4 pole, 5 wire (L1, L2, L3, N & GRND)	25A Service
	240v	3	50/60 hz	14.4	3 pole, 4 wire (L1, L2, L3 & GRND)	50A Service
CE MODEL	230-240v	3	50/60 hz	13.2/14.4	3 pole, 4 wire (L1, L2, L3 & GRND)	50A Service
	380v	3	50/60 hz	14.4	3 pole, 4 wire (L1, L2, L3, N & GRND)	30A Service

* The current draw rating shown above are maximum values for normal operation, amperage draw will be less than the listed value.
Each oven includes a 6 ft cord with NEMA# L6-50P plug. Customer to provide NEMA# L6-50R receptacle.

ALL SPECIFICATIONS SUBJECT TO CHANGE WITHOUT NOTICE.