

PS360G Series
Gas
Domestic & Std. Export
ENGLISH

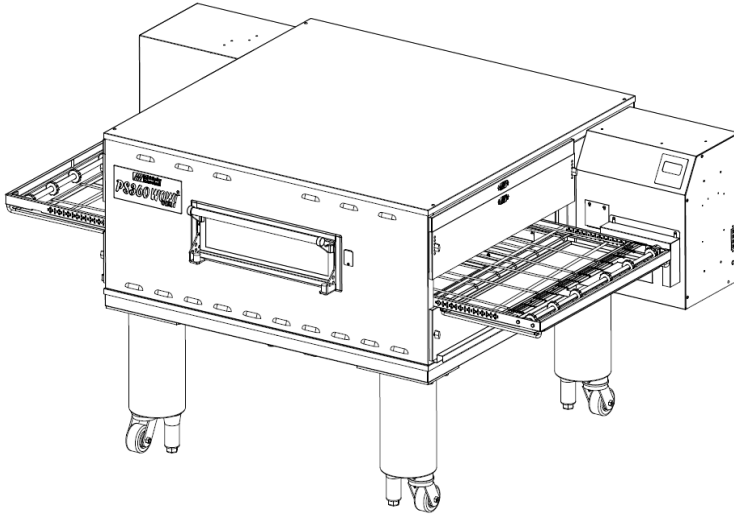

PN 70071, Rev C
March 10, 2014



PS360G Series Gas Ovens

Model:

- PS360G Gas

Combinations:

- Single Oven
- Double Oven (Two-Stack)
- Triple Oven (Three-Stack)

OWNER'S OPERATING AND INSTALLATION MANUAL

for domestic and standard export ovens

© 2014 Middleby Marshall Inc.

 **Middleby
Marshall** is a registered trademark of Middleby Marshall, Inc. All rights reserved.



NOTICE:

This Owner's Operating and Installation Manual should be given to the user. The operator of the oven should be familiar with the function and operation of the oven.

This manual must be kept in a prominent, easily reachable location near the oven.

Ovens are shipped from the factory configured for use with Natural gas. If permitted by local, national and international codes, at the time of installation the oven may be converted to Propane gas operation. This conversion requires the use of a Gas Conversion Kit that is supplied with the oven. For CE-approved ovens, the conversion is described in the *Installation* section of this manual. For domestic and standard export ovens, instructions are included in the Gas Conversion Kit.

It is suggested to obtain a service contract with a Middleby Authorized Service Agent (ASA).

WARNING

POST IN A PROMINENT LOCATION, THE EMERGENCY TELEPHONE NUMBER OF YOUR LOCAL GAS SUPPLIER AND INSTRUCTIONS TO BE FOLLOWED IN THE EVENT YOU SMELL GAS.

Instructions to be followed in the event the user smells gas shall be obtained by consulting the local gas supplier. If the smell of gas is detected, immediately call the emergency phone number of your local gas company. They will have personnel and provisions available to correct the problem.

WARNING

FOR YOUR SAFETY, DO NOT STORE OR USE GASOLINE OR OTHER FLAMMABLE VAPORS AND LIQUIDS IN THE VICINITY OF THIS OR ANY OTHER APPLIANCE.

WARNING

Improper installation, adjustment, alteration, service, or maintenance can cause property damage, injury, or death. Read the installation,

operation, and maintenance instructions thoroughly before installing or servicing the equipment.

WARNING

DO NOT SPRAY AEROSOLS IN THE VICINITY OF THIS APPLIANCE WHILE IT IS IN OPERATION.

IMPORTANT

An electrical wiring diagram for the oven is located inside the machinery compartment.

IMPORTANT

It is the customer's responsibility to report any concealed or non-concealed damage to the freight company. Retain all shipping materials until it is certain that the equipment has not suffered concealed shipping damage.

NOTICE

CONTACT YOUR MIDDLEBY AUTHORIZED SERVICE AGENT TO INSTALL AND PERFORM MAINTENANCE AND REPAIRS AND IF NECESSARY TO CONVERT EQUIPMENT FOR USE WITH OTHER GASES. AN AUTHORIZED SERVICE AGENCY DIRECTORY IS SUPPLIED WITH YOUR OVEN.

NOTICE

Using parts other than genuine Middleby Marshall Factory manufactured parts relieves the manufacturer of all warranty and liability.

NOTICE

Middleby Marshall (Manufacturer) reserves the right to change specifications at any time.

NOTICE

The equipment warranty is not valid unless the oven is installed, started and demonstrated under the supervision of a factory certified installer.

NOTICE

THE EQUIPMENT IS ONLY FOR PROFESSIONAL USE AND SHALL BE USED BY QUALIFIED PERSONNEL.

RETAIN THIS MANUAL FOR FUTURE REFERENCE

MIDDLEBY MARSHALL
NO QUIBBLE LIMITED WARRANTY
(U.S.A. ONLY)

MIDDLEBY MARSHALL, HEREINAFTER REFERRED TO AS "THE SELLER", WARRANTS EQUIPMENT MANUFACTURED BY IT TO BE FREE FROM DEFECTS IN MATERIAL AND WORKMANSHIP FOR WHICH IT IS RESPONSIBLE. THE SELLER'S OBLIGATION UNDER THIS WARRANTY SHALL BE LIMITED TO REPLACING OR REPAIRING AT SELLER'S OPTION, WITHOUT CHARGE, ANY PART FOUND TO BE DEFECTIVE AND ANY LABOR AND MATERIAL EXPENSE INCURRED BY SELLER IN REPAIRING OR REPLACING SUCH PART. SUCH WARRANTY SHALL BE LIMITED TO THE ORIGINAL PURCHASER ONLY AND SHALL BE EFFECTIVE FOR A PERIOD OF ONE YEAR FROM DATE OF ORIGINAL INSTALLATION OR 18 MONTHS FROM DATE OF PURCHASE, WHICHEVER IS EARLIER, PROVIDED THAT TERMS OF PAYMENT HAVE BEEN FULLY MET.

This warranty is valid only if the equipment is installed, started, and demonstrated under the supervision of a factory-authorized installer.

Normal maintenance functions, including lubrication, cleaning or customer abuse, are not covered by this **no quibble warranty**.

Seller shall be responsible only for repairs or replacements of defective parts performed by Seller's authorized service personnel. Authorized service agencies are located in principal cities throughout the contiguous United States, Alaska and Hawaii. This warranty is valid in the 50 United States and is void elsewhere unless the product is purchased through Middleby International with warranty included.

The foregoing warranty is exclusive and in lieu of all other warranties, expressed or implied. There are no implied warranties of merchantability or of fitness for a particular purpose.

The foregoing shall be the Seller's sole and exclusive obligation and Buyer's sole and exclusive remedy for any action, including breach of contract or negligence. In no event shall Seller be liable for a sum in excess of the purchase price of the item. Seller shall not be liable for any prospective or lost profits of the buyer.

This warranty is effective on Middleby Marshall equipment sold on, or after February 15, 1995.

MIDDLEBY MARSHALL
OVEN LIMITED WARRANTY
(Non U.S.A.)

The Seller warrants equipment manufactured by it to be free from defects in material and workmanship for which it is responsible. The Seller's obligation under this warranty shall be limited to replacing or repairing, at Seller's option, without charge, F.O.B. Seller's factory, any part found defective and any labor and material expense incurred by Seller in repairing or replacing such part. Such warranty is limited to a period of one year from the date of original installation or 15 months from date of shipment from Seller's factory, whichever is earlier, provided that terms of payment have been fully met. All labor shall be performed during regular working hours. Overtime premium will be charged to the Buyer.

This warranty is not valid unless equipment is installed, started, and demonstrated under the supervision of a factory-authorized installer.

Normal maintenance functions including lubrication, adjustment of airflow, thermostats, door mechanisms, microswitches, burners and pilot burners, and replacement of light bulbs, fuses, and indicating lights, are not covered by warranty.

Any repair or replacements of defective parts shall be performed by Seller's authorized service personnel. Seller shall not be responsible for any costs incurred if the work is performed by other than the Seller's authorized service personnel.

When returning any part under warranty, the part must be intact and complete, without evidence of misuse or abuse, freight prepaid.

Seller shall not be liable for any consequential damages of any kind which occur during the course of installation of equipment, or which result from the use or misuse by Buyer, its employees or others of the equipment supplied hereunder, and Buyer's sole and exclusive remedy against Seller for any breach of the foregoing warranty or otherwise shall be for the repair or replacement of the equipment or parts thereof affected by such breach.

The foregoing warranty shall be valid and binding upon Seller if and only if Buyer loads, operates and maintains the equipment supplied hereunder in accordance with the instruction manual provided to Buyer. Seller does not guarantee the process of manufacture by Buyer or quality of product to be produced by the equipment supplied hereunder and Seller shall not be liable for any prospective or lost profits of Buyer.

THE FOREGOING WARRANTY IS EXCLUSIVE AND IN LIEU OF ALL OTHER EXPRESS AND IMPLIED WARRANTIES WHATSOEVER, SPECIFICALLY THERE ARE NO IMPLIED WARRANTIES OF MERCHANTABILITY OR FITNESS FOR A PARTICULAR PURPOSE.

The foregoing shall be Seller's sole and exclusive obligation and Buyer's sole and exclusive remedy for any action, whether in breach of contract or negligence. In no event shall Seller be liable for a sum in excess of the purchase price of the item.

TABLE OF CONTENTS

SECTION 1 - DESCRIPTION	Page	SECTION 3 - OPERATION	
I. OVEN USES / MODELS	1	I. DESCRIPTION OF CONTROLS	
II. OVEN COMPONENTS	1	A. Control Keys.....	19
A. Conveyor Motor Drive		B. Display Features.....	20
B. Crumb Pans		II. NORMAL OPERATION	
C. Conveyor		A. Starting the Oven.....	20
D. End Plugs		B. Adjusting the Temperature.....	20
E. Eyebrows		C. Adjusting the Belt Time.....	21
F. Window		D. Turning the Oven OFF.....	21
G. Control Box Door		III. OTHER ADJUSTMENTS (MANAGER MODE)	
H. Serial Plate		A. Changing Blower Speeds.....	21
I. Control Panel		B. Changing Energy Mode Status.....	22
J. Photo Eye		C. System Setup.....	22
K. Gas Burners		1. Actual temperature display	
L. Blowers		2. Set temperature lock	
M. Air Fingers		3. Belt time lock	
III. OVEN SPECIFICATIONS.....	2	4. Degrees Celsius or Fahrenheit.	
A. Dimensions	2	D. Energy Management Information.....	23
B. General Specifications	2	IV. TROUBLESHOOTING INFORMATION	
C. Electrical Specifications	2	A. Troubleshooting Guide.....	24
D. Gas Specifications	2	B. Alerts, Errors and Remedies.....	25
SECTION 2 - INSTALLATION		SECTION 4 - MAINTENANCE	
I. GENERAL	3	I. MAINTENANCE – DAILY.....	26
II. REQUIRED KITS & EQUIPMENT.....	4	II. MAINTENANCE – MONTHLY.....	27
II. BASE/TOP KITS		III. MAINTENANCE – 3 MONTH.....	28
A. SINGLE OVEN BASE/TOP KIT	5	IV. MAINTENANCE – 6 MONTH.....	29
B. DOUBLE OVEN BASE/TOP KIT	6	V. KEY SPARE PARTS.....	30
C. TRIPLE OVEN BASE/TOP KIT	7	SECTION 5 – WIRING DIAGRAMS.....	31–32
III. OVEN LAYOUTS			
A. SINGLE OVEN LAYOUT	8		
B. DOUBLE STACKED LAYOUT	9		
C. TRIPLE STACKED LAYOUT	10		
IV. VENTILATION SYSTEM.....	11		
A. Requirements	11		
B. Recommendations	11		
C. Other Ventilation Concerns	11		
V. ASSEMBLY			
A. Top Panel and Base Pad Assembly.....	12		
B. Stacking	13		
C. Restraint Cable Installation.....	13		
D. Conveyor Installation	14		
VI. ELECTRICAL SUPPLY	15		
VII. GAS SUPPLY			
A. Gas Rough-In Recommendations.....	16		
B. Connection.....	17		
C. Gas Conversion.....	17		
D. Propane Conversion.....	17		
E. Adjusting Max Pressure Setting.....	17		
F. Adjusting Min Pressure Setting.....	18		
G. Checkout.....	18		
H. Maintenance.....	18		

SECTION 1 - DESCRIPTION

I. OVEN USES

The PS360G Series ovens can be used to bake and/or cook a wide variety of products, such as pizza, pizza-type products, cookies, sandwiches and others.

II. OVEN COMPONENTS – See Figure 1-1

- A. **Conveyor Drive Motor (inside cabinet):** Moves the conveyor
- B. **Crumb Pans:** Catch crumbs and other materials that drop through the conveyor belt. One crumb pan is located at each end of the conveyor belt.
- C. **Conveyor:** Moves the food product through the oven.
- D. **End Plugs:** Allow access to the oven's interior.
- E. **Eyebrows:** Can be adjusted to various heights to lessen heat loss to the environment
- F. **Window:** Allows the user to access the food products within the baking chamber, or place product into the oven for shorter bake times.
- G. **Control Cabinet Doors:** Allow access to the oven's control components. No user serviceable parts are located within these cabinets.
- H. **Serial Plate:** Provides specifications for the oven pertinent to installation, operation and maintenance. Refer to *SECTION 2 – INSTALLATION* for details.
- I. **Control Panel (User Interface):** Allows user to adjust temperature, bake time and top and bottom air flow. Also provides diagnostic messages for oven operation.
- J. **Photo Sensor:** Puts oven into the Baking Mode when the beam is interrupted by product being placed on the belt.
- K. **Door Photo Sensor:** Puts oven into the Baking Mode when the beam is interrupted by the front window being opened to insert product.
- L. **Circuit Breaker Resets:** Permits resetting breakers inside cabinet without opening door or touching the circuit breakers directly.
- M. **Gas Burner (inside left control cabinet):** Heat recirculating air within the oven cavity.
- N. **Blowers (not shown):** move heated air that recirculates through the oven cavity.
- O. **Fingers (inside top and bottom of oven cavity):** Direct air in controlled fashion to the product being baked through a pattern arrangement of extruded holes.

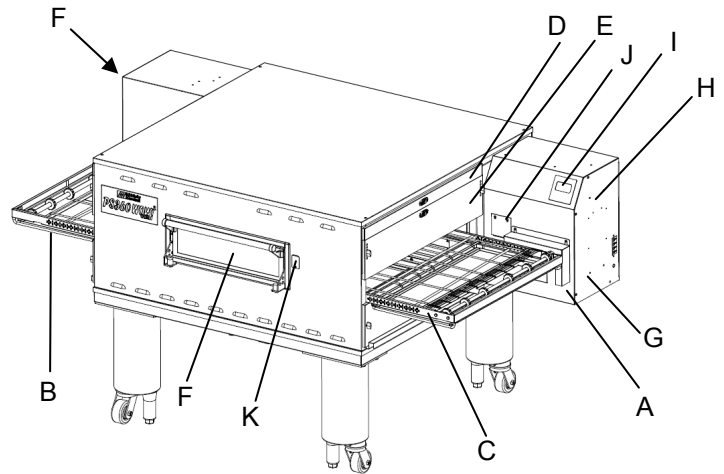

III. OVEN SPECIFICATIONS – PS360G

Table 1-1 Dimensions	Single Oven	Double Oven	Triple Oven
Overall Height	48.52" (1232.4 mm)	68.21" (1732.5 mm)	80.53" (2045.5 mm)
Overall Depth	57.40" (1458 mm)	57.40" (1458 mm)	57.40" (1458 mm)
Overall Length	92.00" (2337 mm)	92.00" (2337 mm)	92.00" (2337 mm)
Conveyor Width – Belt width is 32"	33.5" (850.9 mm)	33.5" (850.9 mm)	33.5" (850.9 mm)

Recommended Minimum Clearances

Rear of Oven to Wall	0" (0 mm)
Right Side of Oven to Wall	2" (50.8 mm)
Left Side of Oven to Wall	2" (50.8 mm)

Table 1-2: General Specifications 32" Belt

Weight	1,100 lbs.
Rated Heat Input (per oven cavity)	119,900 BTU/hr
Maximum Operation Temperature	600°F
Air Blowers	4 at 2,800 rpm
Warm-up Time	20 minutes to 500°F

Table 1-3: Electrical Specifications

Main Blower Voltage	Control Circuit Voltage	Phase	Frequency	Current Draw	Poles	Wires
230 VAC, 3φ	24VDC	1	50-60 Hz	7 Amps	2	3 Wire – L1, L2/N & GRND

Table 1-4: Gas Orifice and Pressure Specifications

Gas Type	Main Orifice Diameter	Inlet Pressure	Manifold Pressure	Bypass Pressure
Natural	.120" (#31)	6-8" W.C. (14.9 - 19.9 mbar)	3.5" W.C. at manifold (8.7 mbar)	0.35-0.36" W.C. at manifold (0.9 mbar)
Propane	.0748" (1.90mm)	11-14" W.C. (27.4 – 34.9 mbar)	10.0" W.C. (24.9 mbar)	0.9-1.0" W.C. (2.2-2.5 mbar)

GAS ORIFICE AND PRESSURE SPECIFICATIONS (PER OVEN CAVITY) – CE OVENS

Gas Type	Main Orifice Diameter	Orifice										Orifice Manifold Pressure	Rated Heat Input
		I _{2H}	I _{2L}	I _{2E}	I _{2E+}	I _{3P}	I _{3P}	I _{3B/P}	I _{3B/P}	I _{3B/P}	I ₃₊		
Natural	.120"	20mbar	--	20	20/25	--	--	--	--	--	--	3.5" w.c.	35.2kW
G20	3.048 mm	--	--	mbar	mbar	--	--	--	--	--	--	8.7mbar	35.2kW
Natural	.120"	--	25	--	--	--	--	--	--	--	--	3.5" w.c.	35.2kW
G25	3.048 mm	--	mbar	--	--	--	--	--	--	--	--	8.7mbar	35.2kW
Butane	.0748"	--	--	--	--	--	--	28-30/50	30	37/50	28-30	10.0" w.c.	35.2kW
G30	1.90mm	--	--	--	--	--	--	mbar	mbar	mbar	mbar	24.9 mbar	35.2kW
Propane	.0748"	--	--	--	--	37	50	--	30	37/50	37	10.0" w.c.	35.2kW
G31	1.90mm	--	--	--	--	mbar	mbar	--	mbar	mbar	mbar	24.9 mbar	35.2kW

NOTE

Wiring Diagrams are contained in Section 5 of this Manual and are also located inside the oven control compartment. Additional electrical information is provided on the oven's serial plate.

THIS MANUAL MUST BE KEPT FOR FUTURE REFERENCE

SECTION 2 - INSTALLATION

I. GENERAL

WARNING – After any conversions, readjustments, or service work on the oven:

- Perform a gas leak test
- Test for correct air supply, particularly to the burner blower.
- Test for proper combustion and gas supply
- Check that the ventilation system is in operation

WARNING – Keep the appliance area free and clear of combustibles.

WARNING – The oven must be installed on an even (level) non-flammable flooring and any adjacent walls must not be flammable. Recommended minimum clearances are specified in the Description section of this manual.

WARNING – Do not obstruct the flow of ventilation air to and from your oven. There must be no obstruction around or underneath the oven. Constructional changes to the area where the oven is installed shall not affect the air supply to the oven.

CAUTION: To reduce the risk of fire, the appliance is to be mounted on floors of non-combustible construction with noncombustible flooring and surface finish and with no combustible material against the underside thereof, or on noncombustible slabs or arches having no combustible material against the underside thereof, such construction shall in all cases extend not less than 12 inches (304 mm) beyond the equipment on all sides.

CAUTION: For additional installation information, contact your local Authorized Service Agent.

NOTE – There must be adequate clearance between the oven and combustible construction. Clearance must also be provided for servicing and proper operation.

NOTE – An electrical wiring diagram for the oven is located inside the machinery compartment.

NOTE: All aspects of the oven installation, including placement, utility connections, and ventilation requirements, must conform to any applicable local, national, or international codes. These codes supersede the requirements and guidelines provided in this manual.

NOTE: In the USA, the oven installation must conform to local codes. In the absence of local codes, gas oven installations must conform to the National Fuel Gas Installation Code, ANSI Z223.1. Gas and electric ovens, when installed must be electrically grounded in accordance with local codes, or in the absence of local codes, with the National Electric Code (NEC), or ANSI/NFPA 70.

NOTE: In Canada, the oven installation must conform to local codes. In the absence of local codes, gas oven installations must conform to the Natural Gas Installation Code, CAN/CGA-B149.1 or Propane Gas Installation Code, CAN/CGA-B149.2, as applicable. Gas and electric ovens, when installed, must be electrically grounded in accordance with local codes, or in the absence of local codes, with Canadian Electrical Code, CSA C22.2.

NOTE: In Australia, the oven installation must conform with local codes. In the absence of local codes, gas oven installation must conform to the requirements of AS5601/AG601, Gas, Electricity, and any other relevant statutory regulations.

II. PS360G OVEN INSTALLATION – REQUIRED KITS & EQUIPMENT

TYPE OF INSTALLATION	PS360G Installation Kit PN 69977	Single Oven Kit Base w/ 15" Legs, Casters & Top PN 69669	Double Oven Kit Base w/ 10" Legs, Casters & Top PN 70051	Triple Oven Kit Base w/ 15" Legs, Casters & Top PN 69997
PS360G Single Gas Oven	1	1	--	--
PS360G Double Gas Oven	2	--	1	--
PS360G Triple Gas Oven	3	--	--	1

PARTS KITS FOR SERIES PS360G GAS OVEN INSTALLATION KIT (PN 69977)

ITEM NUMBER	PART NUMBER	DESCRIPTION	QTY
1	22361-0001	FLEXIBLE GAS HOSE 3/4"	1
2	22450-0228	RESTRAINT CABLE	1
3	50546	TAP AND ADAPTER	1
4	23115-0010	GAS BALL VALVE 3/4 X 3/4	1
5	55027	CONVEYOR END STOP	1
6	61823	CONVEYOR BACK STOP	1

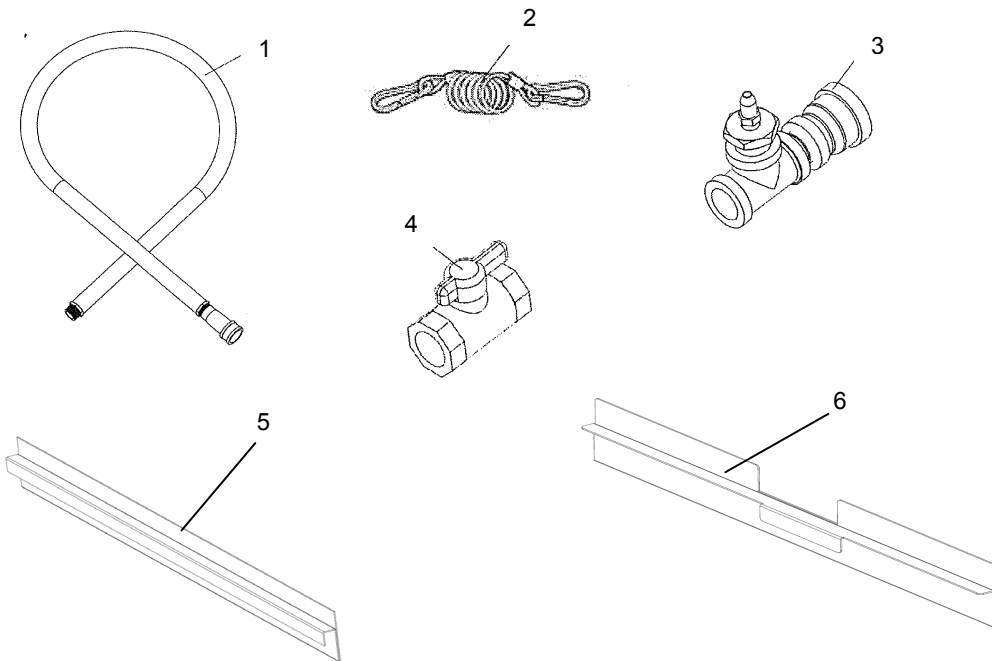

A. PN 69669 – SINGLE OVEN BASE/TOP KIT

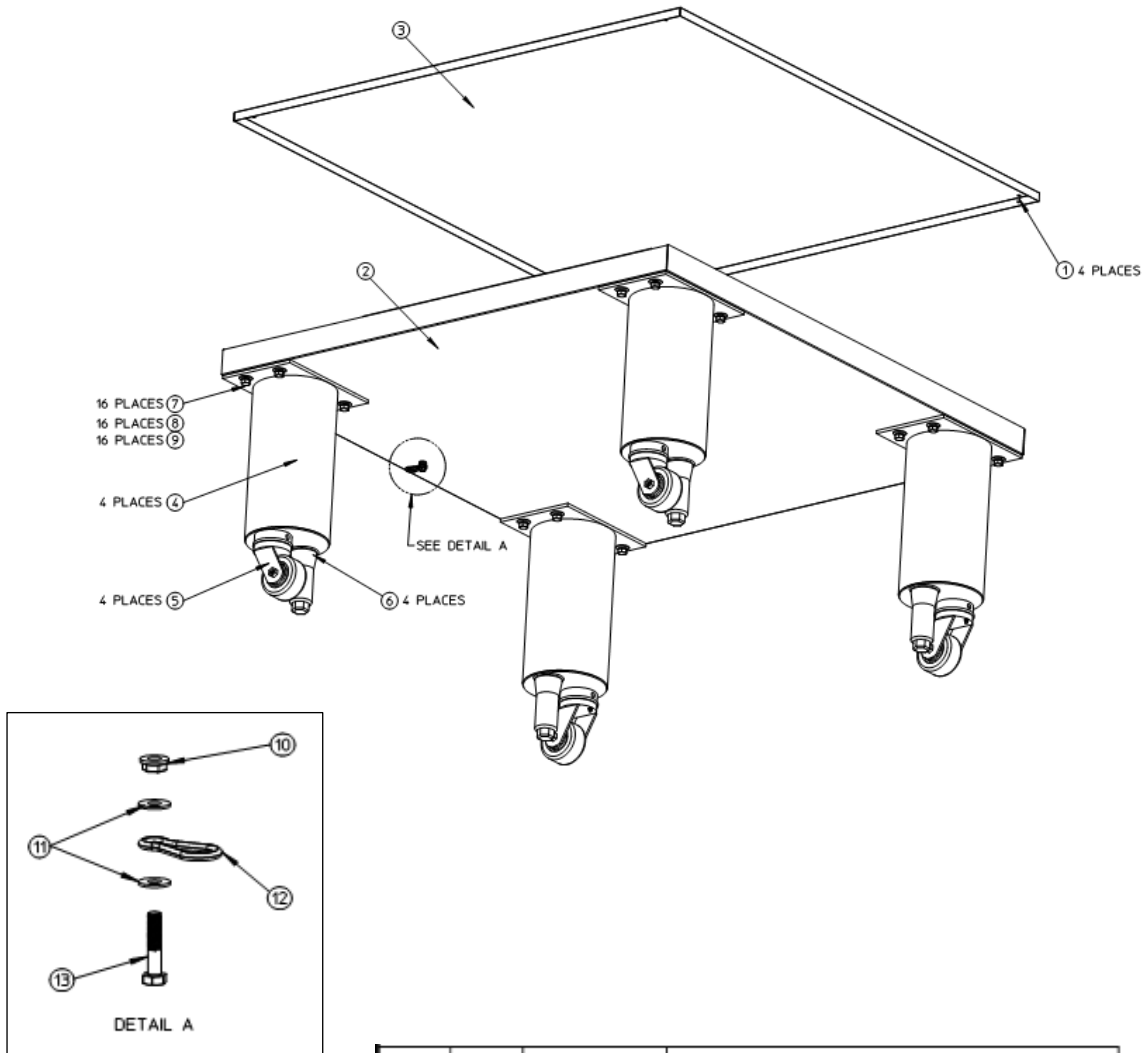

14	1	22450-0228	DEVICE,RESTRAINING (NOTSHOWN) (REF)
13	1	61832	SCREW, HEX 5/16-18 1-1/2"
12	1	61833	CLIP,SPRING 5/16" OPENING
11	2	B301A8847	WASHER,FLAT 5/16 X 3/4 X 1/16
10	1	31239	NUT,HEX FLANGE LOCKING 5/16-18
9	16	21426-0004	WASHER,LOCK 1/2 18-8
8	16	21216-0018	SCR,HHCS 1/2-13X1-1/4 18-8
7	16	21416-0003	WASHER,FLAT 1/2 18-8
6	4	22450-0028	STUD,LEG 6" ADJUST 3/4"
5	4	37115-0102	CASTER,STUD SWVL 2"LX3/4"DIA
4	4	61828	WLDMT, LEG 15"
3	1	68808	PNL,OUTER TOP
2	1	69670	ASSY,BASE 360G
1	4	7A2515	SCR,MS STR TRSHD 10-32X3/4 NP
ITEM	QTY	PART NO.	DESCRIPTION

B. PN 70274 – DOUBLE OVEN BASE/TOP KIT

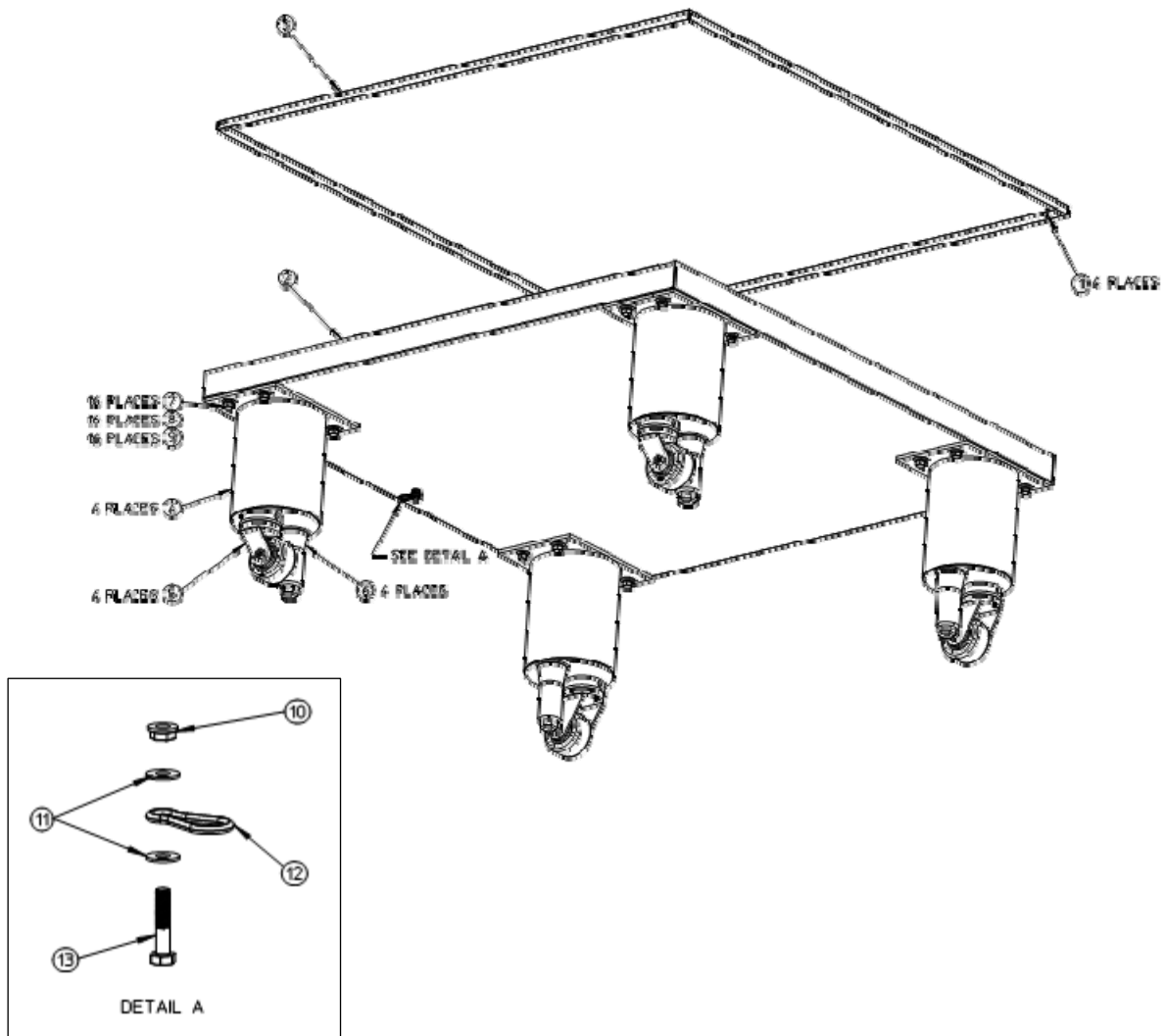

14	1	22450-0228	DEVICE,RESTRAINING (NOTSHOWN) (REF)
13	1	61832	SCREW, HEX 5/16-18 1-1/2"
12	1	61833	CLIP,SPRING 5/16" OPENING
11	2	B301A8847	WASHER,FLAT 5/16 X 3/4 X 1/16
10	1	31239	NUT,HEX FLANGE LOCKING 5/16-18
9	16	21426-0004	WASHER,LOCK 1/2 18-8
8	16	21216-0018	SCR,HHCS 1/2-13X1-1/4 18-8
7	16	21416-0003	WASHER,FLAT 1/2 18-8
6	4	22450-0028	STUD,LEG 6" ADJUST 3/4"
5	4	37115-0102	CASTER,STUD SWVL 2"LX3/4"DIA
4	4	70049	WLDMT, LEG 10"
3	1	68808	PNL,OUTER TOP
2	1	69670	ASSY,BASE 360G
1	4	7A2S15	SCR,MS STR TRSHD 10-32X3/4 NP
ITEM	QTY	PART NO.	DESCRIPTION

C. PN 70275 – TRIPLE OVEN BASE/TOP KIT

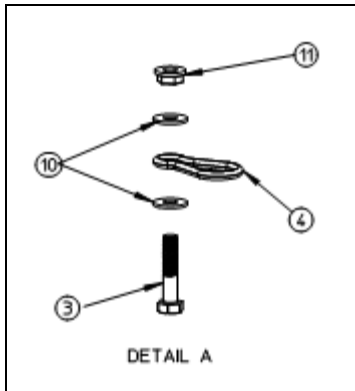
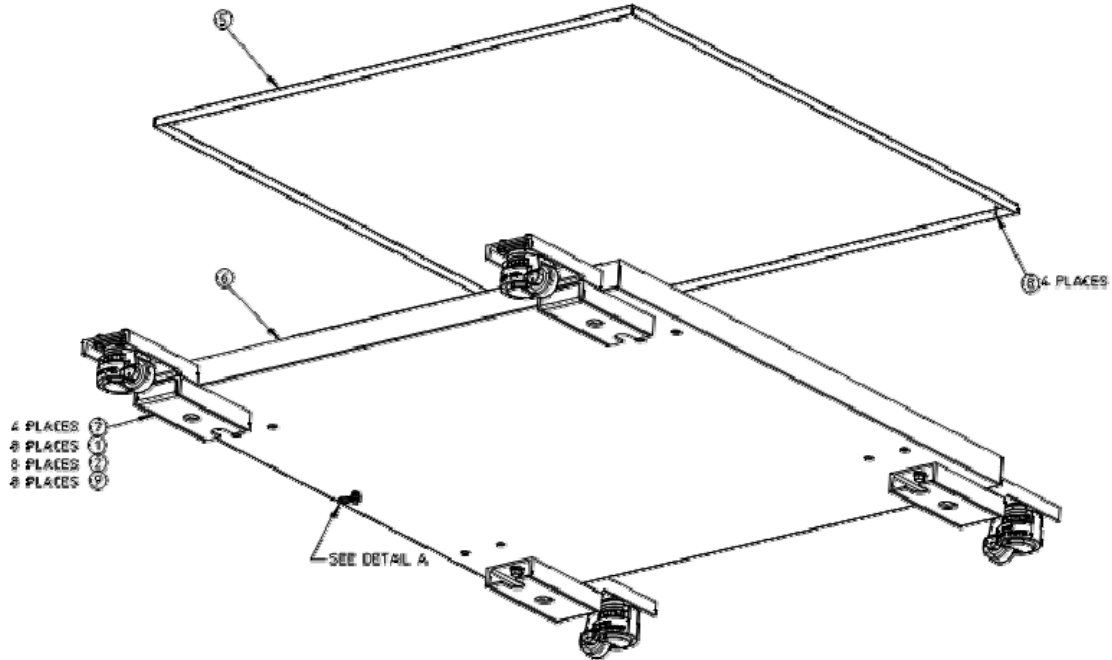

11	1	31239	NUT,HEX 5/16 KEPS
10	2	B301A8847	WASHER,FLAT 5/16 X 3/4 X 1/16
9	8	A27750	WASHER,FLAT .531X1.00X.062
8	4	7A2S15	SCR,MS STR TRSHD 10-32X3/4 NP
7	4	70059	ASSY.OUTRIGGER LEVELING CASTER
6	1	69670	ASSY,BASE 360G
5	1	68808	PNL,OUTER TOP
4	1	61833	CLIP,SPRING 5/16" OPENING
3	1	61832	SCREW, HEX 5/16-18 1-1/2"
2	8	21422-0016	WASHER,LOCK PT 1/2 SPLIT
1	8	2001048	SCR,CAP HX HD 1/2-13X1-3/8 ZP
ITEM	QTY	PART NO.	DESCRIPTION

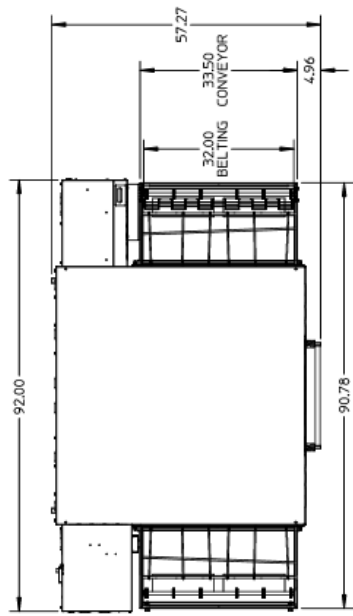

PS360G SINGLE OVEN

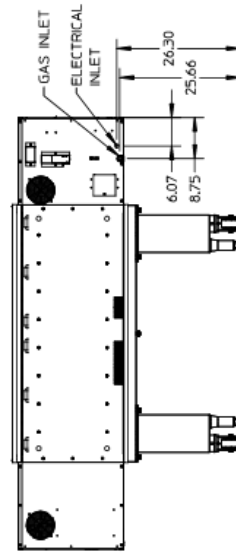
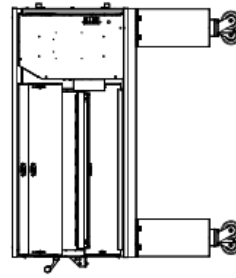
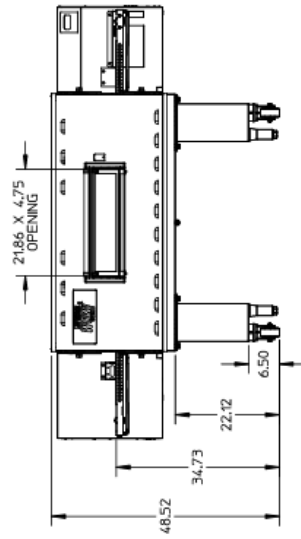

PS360G DOUBLE STACK OVEN

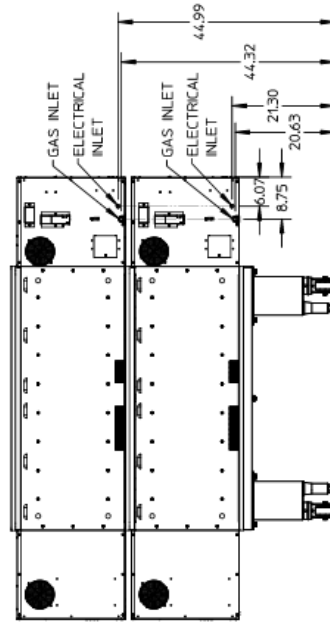
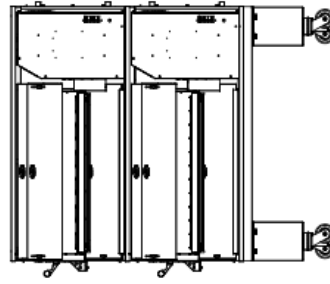
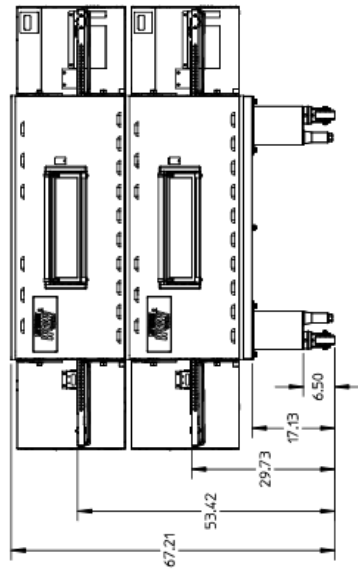
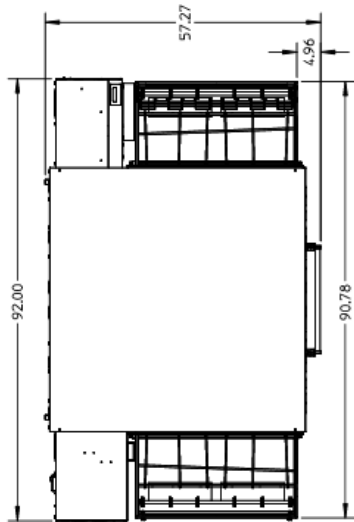

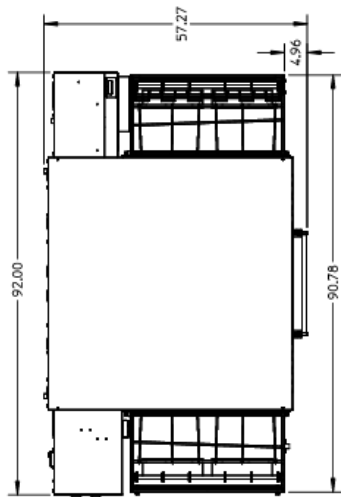

PS360G TRIPLE STACK OVEN

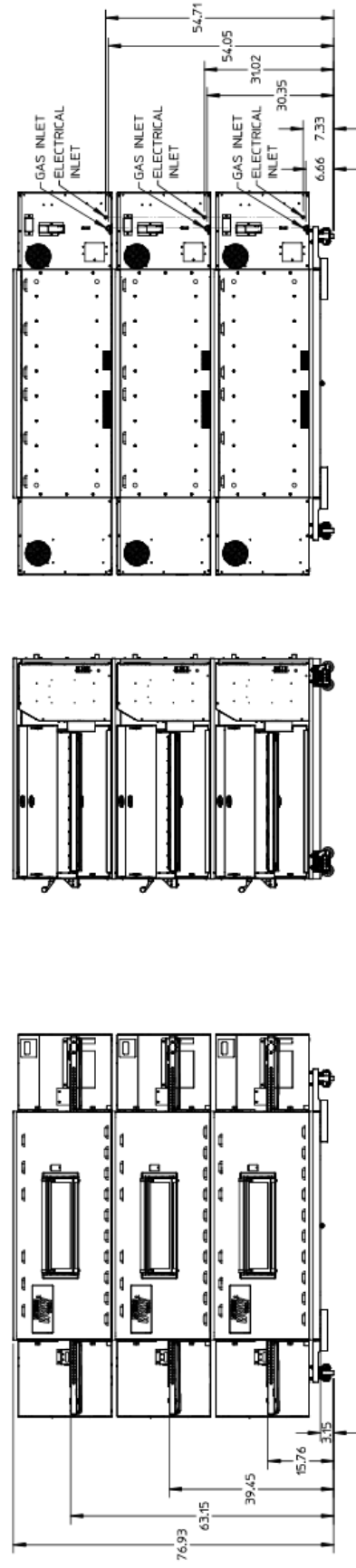

IV. VENTILATION SYSTEM

IMPORTANT

Where national or local codes require the installation of fire suppression equipment or other supplementary equipment, **DO NOT** mount the equipment directly to the oven.

MOUNTING SUCH EQUIPMENT ON THE OVEN MAY:

- VOID AGENCY CERTIFICATIONS
- RESTRICT SERVICE ACCESS
- LEAD TO INCREASED SERVICE EXPENSES FOR THE OWNER

A. Requirements

CAUTION: *Gas oven installations REQUIRE a mechanically driven ventilation system with electrical air sensing control.*

A mechanically driven ventilation system is **STRONGLY RECOMMENDED** for electric oven installations.

PROPER VENTILATION OF THE OVEN IS THE RESPONSIBILITY OF THE OWNER.

B. Recommendations

NOTE THAT THE HOOD DIMENSIONS SHOWN IN FIGURE X-X ARE RECOMMENDATIONS ONLY. LOCAL, NATIONAL, AND INTERNATIONAL CODES MUST BE FOLLOWED WHEN INSTALLING THE VENTILATION SYSTEM. ANY APPLICABLE CODES SUPERCEDE THE RECOMMENDATIONS SHOWN IN THIS MANUAL. IN AUSTRALIA, COMPLIANCE TO REGULATIONS AS5601/AG601 IS MANDATORY.

The rate of air flow exhausted through the ventilation system may vary depending upon the oven configuration and hood design. Consult the hood manufacturer or ventilation engineer for these specifications.

To avoid negative pressure condition in the kitchen area, return air must be brought back to replenish the air that was exhausted. A negative pressure in the kitchen can cause heat related problems to the oven components as if there were no ventilation at all. The best method of supplying return air is through heating, ventilation and air conditioning (HVAC) system. Through the HVAC system, the air can be temperature-controlled for summer and winter. Return air can also be brought in directly from outside the building, but detrimental effects can result from extreme seasonal hot and cold temperatures from the outdoors.

NOTE: Return air from the mechanically driven system must not blow at the opening of the baking chamber. Poor oven baking performance will result.

C. Other ventilation concerns

1. Special locations, conditions, or problems may require the services of a ventilation engineer or specialist.
2. Inadequate ventilation can inhibit oven performance.
3. It is recommended that the ventilation system and duct work be checked at prevailing intervals as specified by the hood manufacturer and/or HVAC engineer or specialist.

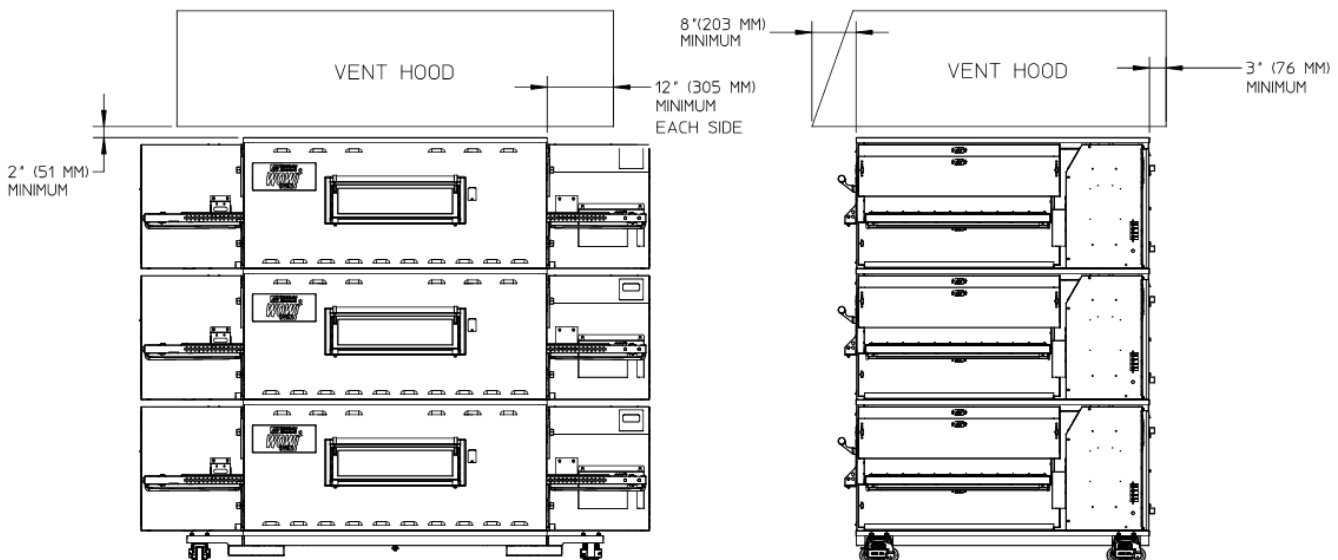

FIG 2-5. Ventilation System Dimensional

V. ASSEMBLY

A. Top Panel and Base Pad Assembly

1. Install the four leg extensions onto the base pad using the 1/2"-13 x 1-1/4" screws, 1/2" flat washers and 1/2" lockwashers supplied in the Base Pad Kit. See Figure 2-6. Check that the orientation of the adjustable 6" leg holes in the leg bottom is consistent (all to the inside or all to the outside). The adjustable leg mounting hole is closer to the edge of the leg than the caster mounting hole. Install the spring clip for the oven restraining cable to the hole in the bottom middle of the base pad per the DETAIL A of the base pad kit drawing (pages 6-8). This clip will attach to the restraint cable that keeps the oven from moving too far when installed on casters.
2. Install one caster and one adjustable 6" leg onto each leg extension and tighten securely in place.
3. Install the lower oven cavity onto the base pad. See Fig 2-7.
4. For single ovens ONLY:

Install the top panel using the screws included in the base pad kit, as shown in Fig 2-8. Then, skip ahead to Part C, Restraint Cable Installation.

For double or triple ovens:

Continue on to Part B, Stacking. Note that the top panel should NOT be installed for double and triple ovens until after stacking the oven cavities.

Fig 2-6. Leg Extension and Caster Installation

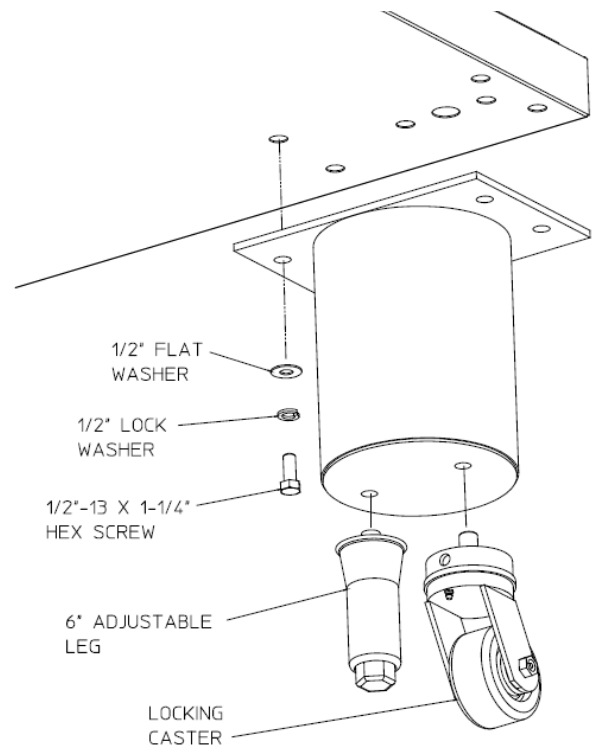

Fig 2-7. Base Pad Installation

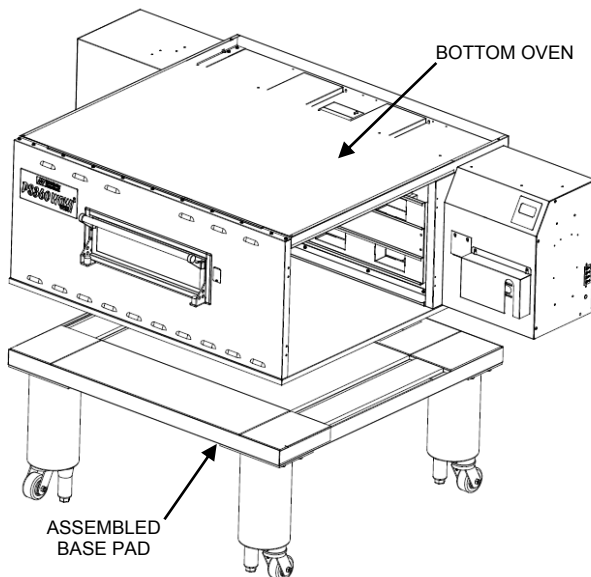
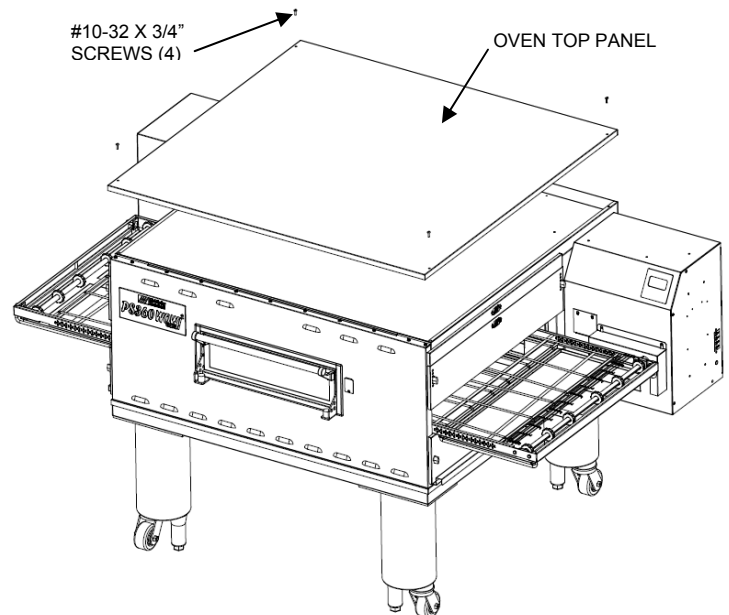

Figure 2-8. Top Panel Installation



NOTE: DO NOT install top panel onto double or triple ovens until AFTER stacking the oven cavities. See Part B, Stacking.

B. Stacking

For single ovens, skip ahead to Part C, Restraint Cable Installation.

IMPORTANT

Middleby Marshall STRONGLY RECOMMENDS that the PS360G Gas oven cavities be stacked by AUTHORIZED PERSONNEL.

Contact your Middleby Marshall authorized Service Agent for complete stacking instructions.

- Stack an oven cavity on top of the lower oven. Check the following:
 - Insulation is installed on the lower oven top.
 - All four sides of the lower lip (on the bottom edge of the oven cavity) overlap the top of the lower oven
 - The oven is level
 - The oven is firmly seated and the top insulation layer is installed smoothly and fully covering the metal panel.

See Figure 2-9.

- For triple ovens, repeat Step 1 to install the top oven cavity.
- Install the top panel using the screws included in the base pad kit, as shown in Figure 2-10.

Figure 2-9. Stacking

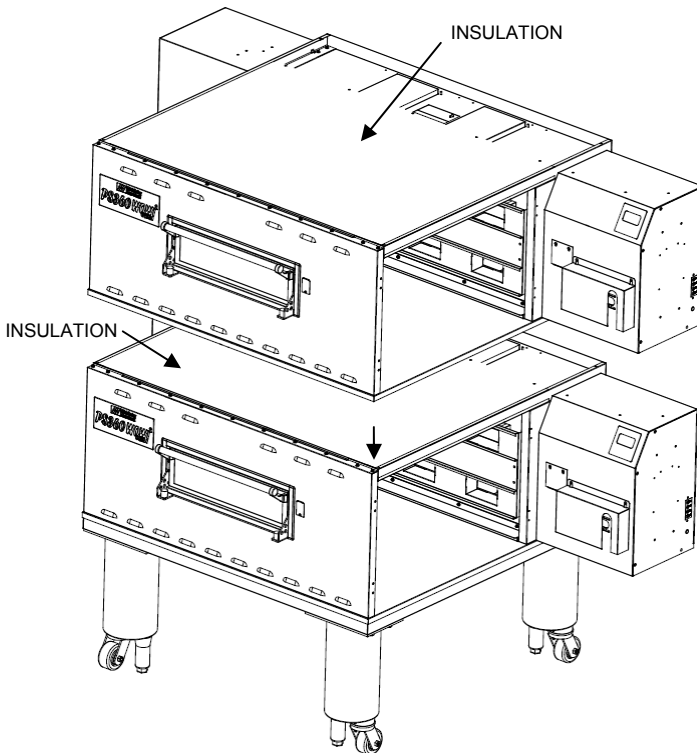

C. Restraint Cable Installation

Because the oven is equipped with casters, a restraint cable assembly must be installed to limit the movement of the appliance without depending upon the connector and the quick disconnect device or its associated piping. One end of the cable is anchored to the snap clip on the underside of the base pad while the other is anchored to the wall.

After connecting the restraint cable, move the oven to its final location. Adjust the bottom (hex) sections of the adjustable legs so that the casters are off the floor. For triple ovens, lock the two front casters.

FIGURE 2-10. Top Panel Installation

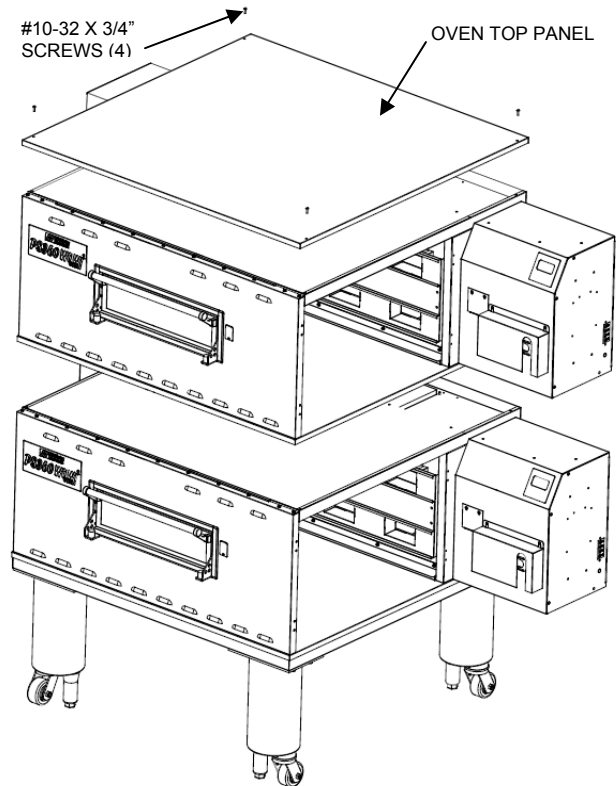
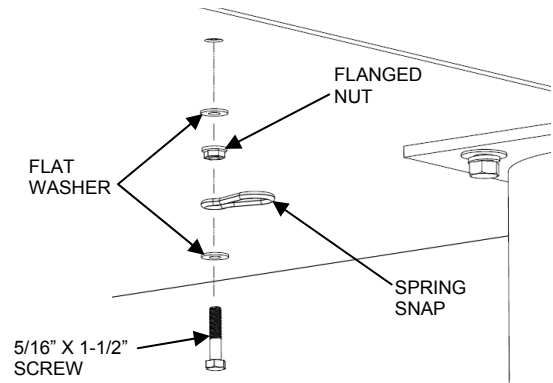

FIGURE 2-10. Installing the Restraint Cable



The restraint cable is connected to the spring snap located at the back-center of the base underside. The 3/4" eyebolt must be anchored to the wall or floor to attach the other end of the restraint cable.

D. Conveyor Installation

1. Unfold the conveyor as shown in Figure 2-12. Then begin to slide the conveyor into the end of the oven. The conveyor can only be installed from the side of the oven where the drive motors are located.
2. Continue moving the conveyor into the oven until the frame protrudes equally from each end of the oven. Check that the crumb tray supports located on the underside of the conveyor frame rests firmly against the lower end plugs, as shown in Figure 2-13.
3. When the conveyor is positioned properly, check for freedom of movement of the conveyor belt by pulling it for about 2 to 3 feet (0.6- 1.0 m) with your fingers. The drive and idler shafts must rotate smoothly, and the belt must move freely without rubbing on the inside of the oven.
4. Check the Tension of the conveyor belt as shown in Figure 2-14. The belt should lift about 1" (25mm). **DO NOT OVER TIGHTEN THE CONVEYOR BELT.**

NOTE: If necessary, the belt tension can be adjusted by turning the conveyor adjustment screws, located at the idler (non-control) end of the conveyor. See Figure 2-14.

Figure 2-12. Conveyor Installation

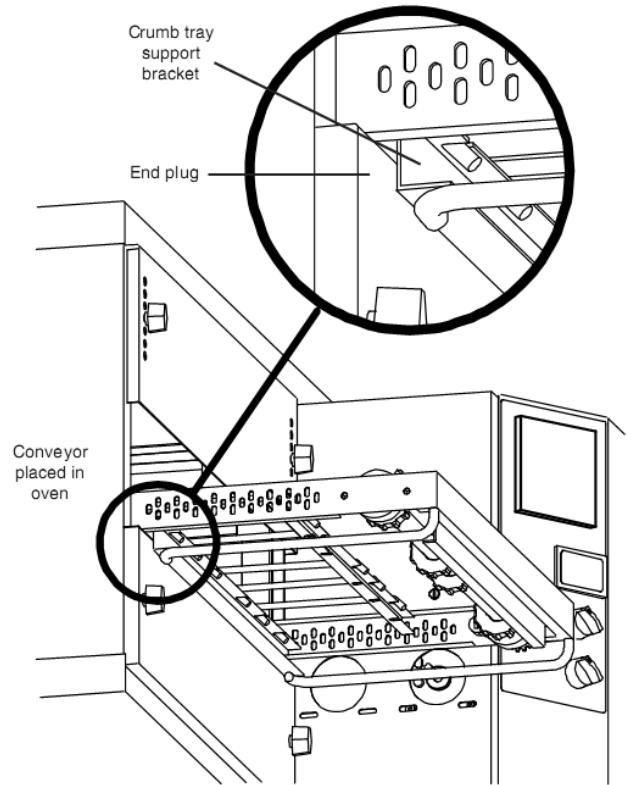
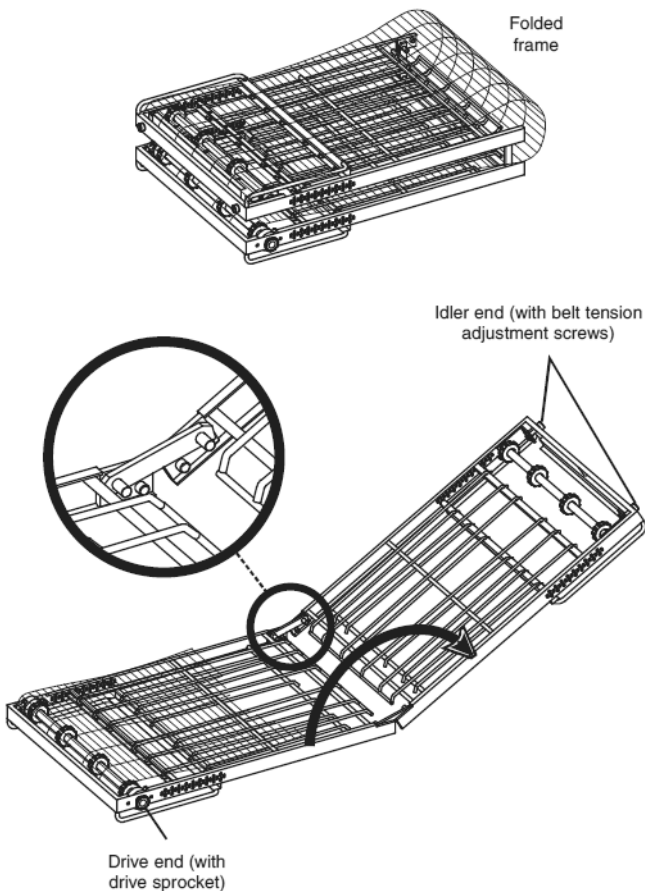
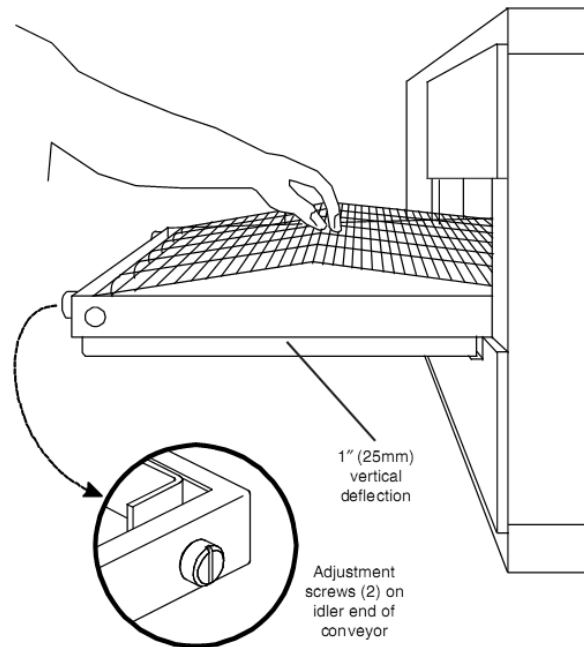

Figure 2-14. Conveyor Belt Tension



5. If it is necessary to add or remove conveyor links to achieve the correct tension, OR if it is necessary to reverse the conveyor belt for correct orientation, the belt will need to be removed from the conveyor frame. If this is necessary, perform the following procedure:

- Remove the conveyor assembly from the oven and place it flat on the floor.
- Remove the master links using long-nose pliers. Then, roll up the belt along the length of the conveyor frame.
- Add or remove belt links as necessary to achieve the correct belt tension.
- Replace the belt on the conveyor frame. Check that the conveyor belt links are oriented as shown in Figure 2-15, and that the smooth side of the conveyor belt faces UP.
- Connect the inside master links. Check that the links are oriented as shown in Figure 2-15.
- Connect the outside master links. Note that the outside master links each have an open hook on one side. This hook aligns with the hooks along the sides of the other conveyor links. See Figure 2-15.
- Replace the conveyor into the oven.

Figure 2-15. Conveyor and Master Link orientation

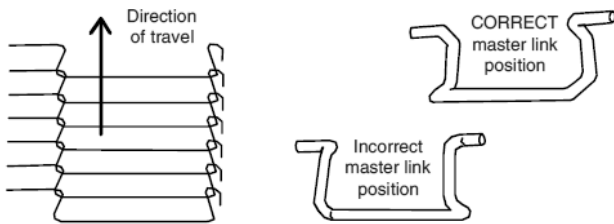

E. Final Assembly

1. Install the crumb trays underneath the conveyor as shown in Figure 2-16.

Figure 2-16. Crumb Trays

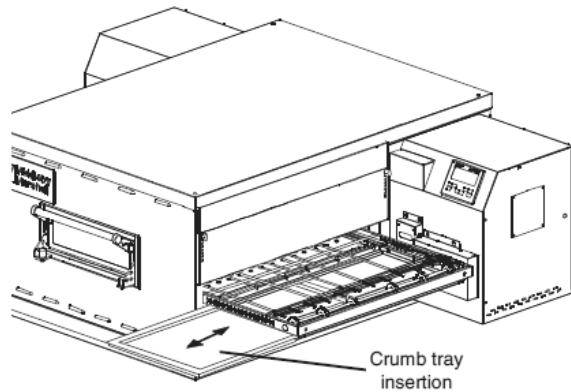

CONVEYOR BELT REVERSAL

Conveyor belt reversal consists of three steps:

1. Physically reversing the conveyor belt
2. Resetting the conveyor travel direction through the User Interface.
3. Switching the photo sensor.

REVERSING THE CONVEYOR BELT

Remove the conveyor from the oven and find the master link location. Remove master links and remove the belt from the conveyor frame. Reassemble the belt back onto the frame (in the reverse direction) and reinstall the master links. Replace the conveyor assembly in the oven.

RESETTING DIRECTION

See OVEN CONFIGURATION MENU in the PS360G TECH GUIDE. Direction is changed through the User Interface with no wiring changes necessary.

CAUTION: Shock hazard in compartments electrical filters are electrically alive.



SWITCHING PHOTO SENSOR

CAUTION: Disconnect power before switching Photo Eye.



Remove the three screws securing the access door to the unit. Open the access door and disconnect the connector fitting to the photo eye assembly. Remove the two screws securing the photo eye assembly to the control box. Remove the four nuts securing the photo eye to the housing. Rotate the photo eye 180 degrees and affix the photo eye with the four nuts. On the opposite control box, remove the two screws holding the cover where the photo eye assembly will be positioned. Secure the photo eye assembly in position with the two screws. Place the photo eye cover on the opposite control box, where the photo eye assembly was removed, and secure the two screws. Secure the access door with the three screws. Remove the three screws securing the access door on the opposite side. Open the access door, where the photo eye is now positioned, and connect the photo eye connector fitting. Secure the access door with the three screws. Apply power to the unit. Adjust the photo eye height by loosening the two screws securing the photo eye assembly and sliding the photo eye assembly either up or down, such that the beam is approximately 1/4 inch above the belt.

Note: This is MUCH easier in reduced light.

Replace all covers.

VI. ELECTRICAL SUPPLY

CAUTION: Authorized installation personnel normally accomplish the connections for the ventilation system, electric supply, and gas supply, as arranged by the customer. Following these connections, the factory-authorized installer can perform the initial startup of the oven.



NOTE: The electric supply installation must satisfy the requirements of the appropriate statutory authority such as the National Electrical Code, CSA C22.2; the Australian Code AG601; or other applicable regulations.

NOTE: The electric supply connection must meet all national and local electrical code requirements.

Figure 2-17. Utility Connection Locations

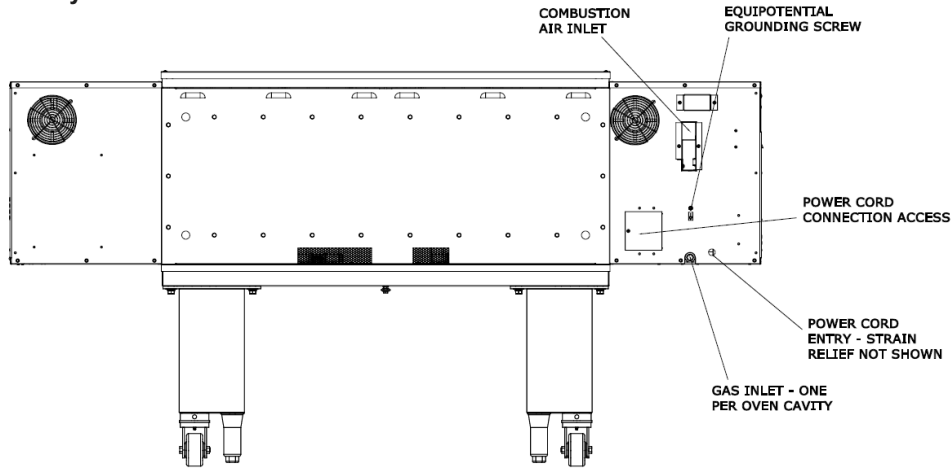

Check the oven serial plate before making any electric supply connections. Electric supply connections must agree with data on the oven serial plate. The location of the serial plate is shown in Figure 1-1 (in Section 1, [Description](#)).

A fused disconnect switch or a main circuit breaker (customer furnished) **MUST** be installed in the electric supply line for each oven cavity. It is recommended that the switch/circuit breaker have Lockout/Tagout capability.

The supply conductors must be of the size and material (copper) recommended. Refer to the wiring diagram inside the machinery compartment of the oven. Electrical specifications are also listed on the oven's serial plate and in Table 1-3, [Electrical Specifications](#) (in Section 1, [Description](#)).

The oven requires a ground connection to the oven ground screw. For gas ovens, the screw is located in the electrical junction box (see Figure 2-14). If necessary, have the electrician supply the ground wire. Do **NOT** use the wiring conduit or other piping for ground connections.

Incoming electrical power lines are fed through the strain-relief fitting, shown in Figure 2-14. The electrical supply connections are made inside the electrical junction box. The power lines then connect to the oven circuits through safety switches located inside the machinery compartment and each blower motor compartment. These switches interrupt electrical power to the oven when the Machinery Compartment Access Panel is opened, OR when the rear panel is removed.

Connection

Refer to the wiring diagram inside the machinery compartment of the oven to determine the correct connections for the electrical supply lines. Connect the supply as indicated on the wiring diagram.

CAUTION: *The terms of the oven's warranty require all start-ups, conversions and service work to be performed by a Middleby Marshall Authorized Service Agent.*



VII. GAS SUPPLY

CAUTION: *DURING PRESSURE TESTING NOTE ONE OF THE FOLLOWING:*



1. The oven and its individual shutoff valve must be disconnected from the gas supply piping system during any pressure testing of that system at test pressure in excess of ½ psi (3.45 kPa).
2. The oven must be isolated from the gas supply piping system by closing its individual manual shutoff during any pressure testing of the gas supply piping system at test pressure equal to or less than ½ psi (3.45 kPa).
3. If incoming pressure is over 14" W.C. (35 mbar), a separate regulator **MUST** be installed in the line **BEFORE** the individual shutoff valve for the oven.

CAUTION: To prevent damage to the control valve regulator during initial turn-on of gas, it is very important to open the manual shutoff valve very slowly.



After the initial gas turn-on, the manual shutoff valve must remain open except during pressure testing as outlined in the above steps or when necessary during service maintenance.

A. Gas Utility Rough-In Recommendations

The following system specifications are **STRONGLY RECOMMENDED**. Deviating from these recommendations may affect the baking performance of the oven.

Gas Meter

- One or two cavities: 750 CFH meter
- Three oven cavities: 1,200 CFH meter

Gas Line

- DEDICATED GAS LINE from the gas meter to the oven
- 2" (50.8mm) pipe for Natural gas
- 2" (50.8mm) pipe for Propane
- Maximum length: 2.002 (61m). Each 90° elbow equals 7' (2.13m) of pipe.

B. Connection

Check the oven's gas supply requirements before making the gas utility connections. Gas supply requirements are listed on the oven's serial plate and in Table 1-4. Gas Orifice and Pressure Specifications (in Section 1, Description).

Check the serial plate to determine the type of gas (Propane or Natural) to be used with the oven.

Refer to the instructions in the gas hose package (included in the Installation Kit) before connecting the gas line. One gas line connection method is shown in Figure 2-18; however, compliance with the applicable standards and regulations is mandatory.

Inlet, regulated, and pilot gas pressure readings can be taken using a digital tube manometer at the tap location shown in Figure 2-19. Figure 2-19 shows the burner assembly and Figure 2-21 shows the gas valve.

NOTE: The installation must conform with local codes or in the absence of local codes, to the National Fuel Gas Code, ANSI Z223.1-latest edition.

Figure 2-18. Flexible Gas Hose Installation

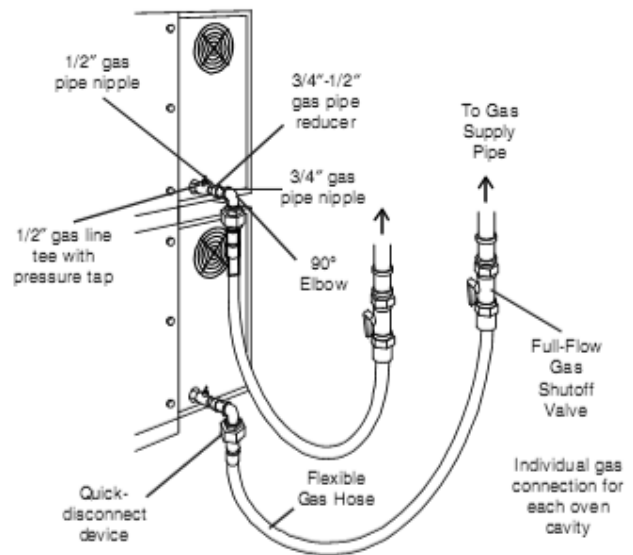

Figure 2-19. Gas Burner Assembly

Certain safety code requirements exist for the installation of gas ovens; refer to the beginning of Section 2 for a list of the installation standards. In addition, because the oven is equipped with casters, the gas line connection shall be made with a connector that complies with the Standard for Connectors for Movable Gas Appliances, ANSI Z21.69 (in U.S.A.), as well as a quick-disconnect device that complies with the Standard for Quick-Disconnect Devices for Use With Gas Fuel, ANSI Z21.41 (in U.S.A.).

C. Gas Conversion

Where permitted by local and national codes, it is possible to convert ovens from natural gas to propane or from propane to natural gas. Use the appropriate Middleby Gas Conversion Kit for the specific oven model.

CAUTION:



The terms of the oven's warranty require all startups, conversions and service work to be performed by a Middleby Authorized Service Agent.

D. PS360G Propane Conversion

Two items must be changed to change the oven to operate on LP:

1. Replace main orifices.
2. Adjust main gas regulator per instructions below.

Disconnect the manifold union closest to the main burner, and remove the manifold assembly (four screws). Slide out the manifold assembly (leaving the ignition and sense wires connected). Replace the main orifices.

Replace the main orifices on the manifold assemblies with the LP units, and replace the manifold assembly. Reconnect the union.

E. Adjusting the Maximum Pressure Setting

1. Disconnect pressure feedback connection (if applicable).
2. Connect a suitable pressure gauge to pipe line or to outlet pressure tap of gas control concerned, to measure burner pressure (measuring point must be as near to burner as possible).

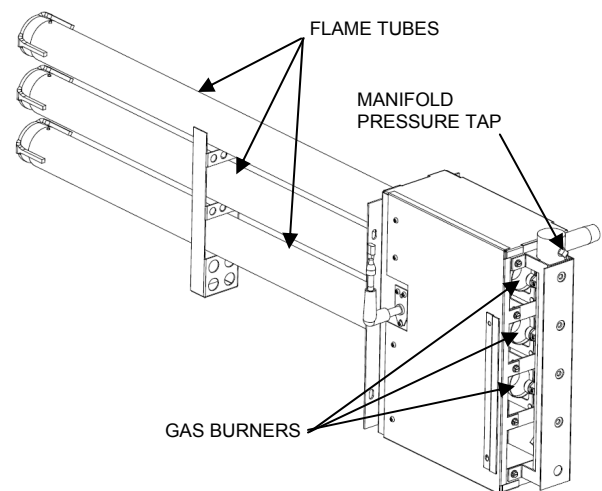

3. Make sure that the appliance is in operation and the Moduplus® coil is energized with maximum current.
4. If maximum rate pressure needs adjustment, use an 8 mm wrench to turn adjustment screw for maximum pressure setting (clockwise to increase or counter-clockwise to decrease pressure), until the desired maximum outlet pressure is obtained.
5. Disconnect electrical connection of the Moduplus®.
6. Check minimum pressure setting and readjust if necessary. (See Adjusting Minimum Pressure Setting for proper adjusting procedure.)
7. Reconnect pressure feedback connection (if applicable).
8. If minimum and maximum pressures are set, wire the Moduplus® in circuit.
9. Close pressure tap screw.

Figure 2-20. Burner Components

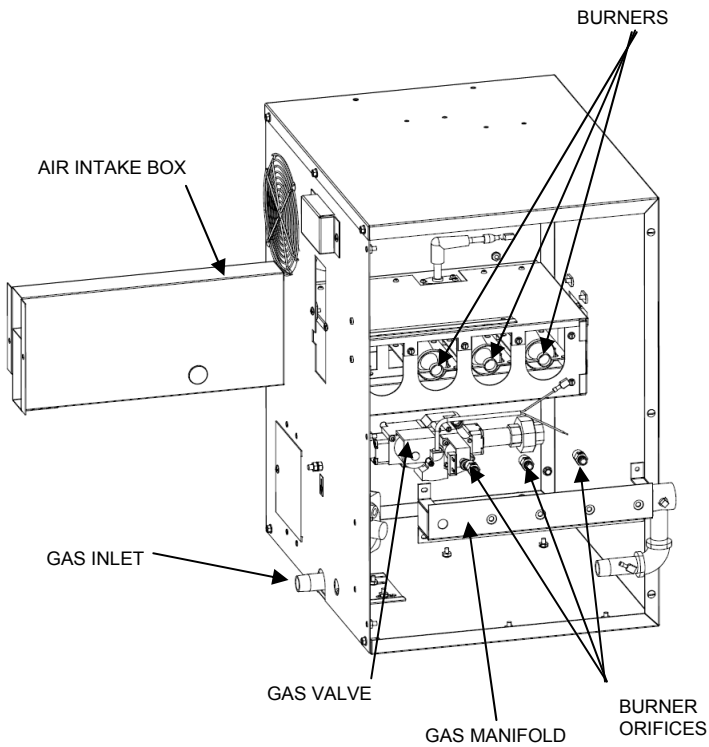

5. If minimum rate pressure needs adjustment, use an 8 mm wrench to turn adjustment screw for minimum pressure setting (clockwise to increase or counter-clockwise to decrease pressure), until the desired minimum outlet pressure is obtained.
6. Check if main burner lights easily and reliably at minimum pressure.
7. Reconnect pressure feedback connection (if applicable).
8. Close pressure tap screw.

G. Checkout

After any adjustment, set appliance in operation and observe through a component cycle to ensure that burner system components function correctly.

NOTE: The installer **MUST** verify oven operation prior to putting oven into service.

H. Maintenance

It is recommended to check yearly the minimum and the maximum setting and readjust them if necessary.

Figure 2-21. Gas Valve

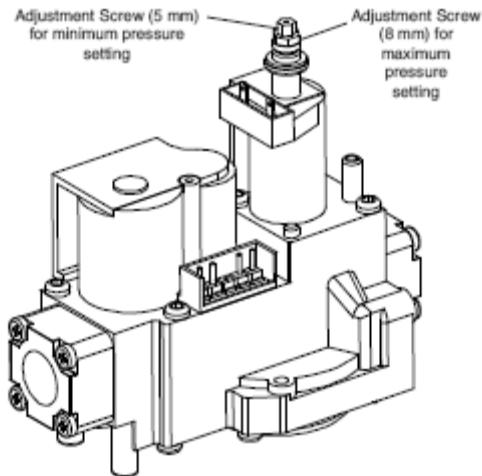

F. Adjusting the Minimum Pressure Setting

1. Disconnect pressure feedback connection (if applicable).
2. Connect a suitable pressure gauge to pipe line or to outlet pressure tap of gas control concerned, to measure burner pressure (measuring point must be as near to burner as possible).
3. Disconnect electrical connection of the Moduplus®.
4. Energize operator, set control in operation and wait until an outlet pressure is recorded on pressure gauge.

SECTION 3 - OPERATION

I. DESCRIPTION OF CONTROLS – USER INTERFACE

The PS360G oven control performs a variety of functions, including

- Temperature control
- Belt speed control
- Upper/lower blower speed setting
- Energy management
- Oven diagnostics and system testing
- Conveyor speed calibration (Service use only)

The oven control will have power delivered to it and initialize when the oven is connected to the power supply. Upon initialization, the control will briefly display its “WOW OVEN” splash screen, then proceed to OFF mode.

A. Control Keys

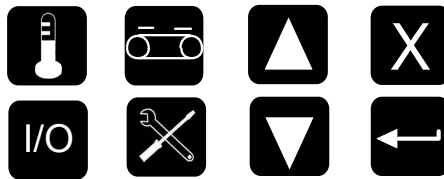

“ON/OFF” key:

- Quick press brings oven to active, “ON” mode.
- Press and hold will put oven into “OFF” mode. If temp is over 200F the blowers will remain on until the oven temp drops below 200F.



“TEMPERATURE” key:

- Quick press displays actual temperature.
- Press and hold until display flashes. Allows change to set temperature.



“BELT” Key:

- Quick press displays alternate front and back belt speeds
- Press and hold until display flashes. Allows change to belt speed.



“UP/DOWN” keys:

- Press up or down to change number values or change parameter.



“TOOLS” Key:

- Press (when off) to enter “Setup” or “test” screens



“CANCEL” Key:

- Quick press cancels last action and returns to last screen or operation.
- Press and hold to shut oven off.



“RETURN” Key:

- Quick press starts oven from off mode.
- Enters and saves changed parameter value.

B. Display Features

STATUS INDICATOR:

“BAKING” appears when the oven is in baking mode. No text here indicates that the oven is in IDLE mode.

SETPOINT:

Set point (baking) temperature is displayed here.



ACTUAL TEMPERATURE:

Actual temperature of the oven is displayed here. If it is not displayed, pressing the TEMPERATURE key momentarily will show the actual temperature for 15 seconds.

BELT DISPLAYED:

“F” indicates FRONT belt time is being displayed. “B” indicates that the BACK belt time is being displayed. If no letter appears the belt times are identical.

BELT SPEED:

Displays time in minutes and seconds that it takes for the belt to travel the length of the baking chamber.

HEAT STATUS:

Alternating display indicates: “HEAT” – heat relay is energized “30%” – “percent of heat” signal from the control to the gas valve

II. NORMAL OPERATION





A. Starting the Oven

To start the oven, press the  button. The oven will start and the operating display will appear on the screen.

The blowers will begin and the blower proving switches will engage, permitting the heat circuit relay to engage. The





gas ignition module will begin its cycle and ignite the three inshot burners.

B. Adjusting the Temperature

To adjust the set temperature, press and hold the  button until the set temperature display flashes. Press the  or  arrow until the desired set temperature is displayed. Press the  button to set and save the new temperature value. If  button is not pressed, the new temperature will be present only until the

oven is turned OFF. The previously used set temperature will appear when the oven is turned ON again.

C. Adjusting the Belt Time

To adjust the belt time, press and hold the  button until the belt time display flashes. Press the  or  button until the desired belt time is displayed. Press the  button to set and save the new time value.

If the  button is not pressed, the new time will be present only until the oven is turned OFF. The previously used set

temperature will appear when the oven is turned ON again.







D. Turning the Oven Off

To turn the oven OFF, press and hold the  button. If the oven is below 200°F the display will show “WOW OVEN” screen. If the oven is above 200°F, the display will show “COOL DOWN” and the blowers will run at a preset cool down speed until the oven temperature falls below 200° at which point the oven will go to the OFF mode. In the OFF mode, the screen will display the “WOW OVEN” screen for a one minute period after which the screen backlight will shut off. The oven will stay in this condition until it is started again, with no outputs energized.





III. OTHER ADJUSTMENTS (Manager Mode)

A. Changing Baking Blower Speeds (Run Mode)

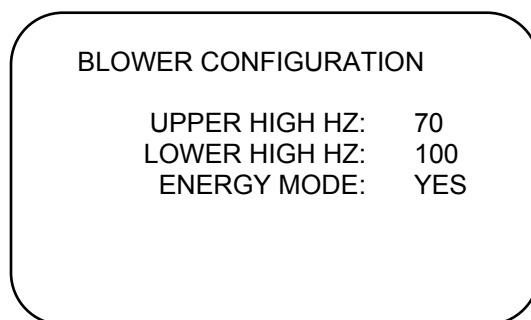
To change the upper or lower blower speeds without turning the oven OFF.

1. Enter the BLOWER CONFIGURATION Screen. Press and hold  key until “PASSWORD” appears on the screen. Press     and . The screen should appear as below.







2. Press  until UPPER HIGH HZ is flashing. Press  to change UPPER HIGH HZ. Press  or  to display the desired value. Press  to accept the new value. Follow same procedure for the LOWER HIGH HZ value if required.

- MINIMUM HZ VALUE: 45 Hz
- MAXIMUM HZ VALUE: 90 Hz

B. Changing Energy Mode Status (Run Mode)

If the photo eye should ever fail to operate, baking mode can be continually engaged by disabling the energy mode. A service call should be made in the interim, as energy use will be considerably higher without the energy mode.

Press  until ENERGY MODE is flashing. Press . Status of energy mode will be flashing (i.e., YES or NO). Press  to change status to desired state. Press  to accept status change. Press  to leave the BLOWER CONFIGURATION screen.

C. System Setup

Enter **SYSTEM SETUP** menu (Can only be done in OFF mode)







Four control system values can be changed that relate to the user interface for the daily oven operator:

1. Actual temperature display always on or off
2. Set temperature lock on or off
3. Belt time lock on or off
4. Degrees Celsius shown, or default degrees Fahrenheit.

Press  key. "PASSWORD" will appear on the screen.

Press     and . The screen should appear as below.

SYSTEM SETUP	
SHOW TEMP ALWAYS:	YES
SET TEMP LOCKED:	NO
SET TIME LOCKED:	NO
CELSIUS:	NO

Press  until the item you want to change is flashing, then press . Now press  until the setting you desire is displayed, then press . Press  to leave the SYSTEM SETUP menu. Press  to return to operating mode.

D. Energy Management Information

The PS360G reduces energy usage in two ways over most competitive ovens:

- Modulating gas control
- IDLE/ BAKING mode control (Energy Saving Mode)

The modulating gas valve within the oven controls pressure of the delivered gas to the burners to increase or reduce the energy input as needed to maintain temperature instead of cycling a gas valve on and off. This is a more efficient and accurate way of controlling the temperature and eliminates the losses associated with the ON/OFF cycling control.









The PS360G like other Middleby WOW ovens has an idle mode that places the blowers at a reduced speed during non-baking periods. Reducing the blower speed reduces the volume of air requiring heating and thus reduces energy usage in these non-baking times. A photo eye sensor at the entrance side of the baking chamber detects when food is placed on the belt and brings the oven up to the higher (baking) blower speed, increasing the amount of convection air needed to cook products faster. When the product passes the photo eye, the controller begins a preset timed period that insures the product will pass fully through the oven before the oven returns to the IDLE mode. With this energy management scheme, the oven provides the increased convection heat transfer needed for fast baking, without the energy penalty during non-baking times. This functionality is fully automatic and requires no user interaction.

IV. PS360G TROUBLESHOOTING INFORMATION

A. Troubleshooting Guide

SYMPTOM	POSSIBLE CAUSES	SOLUTIONS
Nothing displayed on controller	<ol style="list-style-type: none"> 1. Power not connected 2. Main breaker not on 3. Control circuit breaker tripped 	<ol style="list-style-type: none"> 1. Check plug at wall 2. Check main breaker 3. Check control breaker
Control display is dim and the WOW OVEN image can be seen	Control is in OFF/STANDBY mode.	No problem – the control backlight turns off when the oven is not turned on for use. Press I/O button.
Oven not baking properly	<ol style="list-style-type: none"> 1. Settings have been changed 2. Kitchen airflow conditions affecting the bake 	<ol style="list-style-type: none"> 1. Confirm correct values and check that the oven is set properly (time and temperature) 2. Eliminate air cross-currents in area
Conveyor noticeably running at the wrong speed	Time settings have been changed	Confirm correct values and correct control settings
Conveyor not moving	<ol style="list-style-type: none"> 1. Something has jammed the conveyor 2. Circuit breaker (behind control panel) has tripped 3. Chain has come loose from the sprocket 	<ol style="list-style-type: none"> 1. Turn power off. Locate and remove jam item. 2. Check conveyor for jamming and Reset the breaker (right side control door). 3. With power OFF, remove chain cover, replace chain onto sprocket and replace chain cover.
“IGNITION LOCKOUT” on display	<ol style="list-style-type: none"> 1. Gas not turned on to oven 2. Burner has stopped running 	<ol style="list-style-type: none"> 1. Turn on manual valve on supply to oven 2. Turn the oven off and back on again to clear the notification and relight <ul style="list-style-type: none"> • Arrange for service if the problem reoccurs
“BAKING” indication goes on and off in upper left corner of the control display	Oven is cycling normally. BAKING indication comes on upon triggering the photo eye.	No problem – the timed baking cycle automatically starts when product breaks the photo eye beam and stops after product leaves the baking chamber.
Oven does not enter BAKING mode when product is placed on the belt.	Photo eye not working.	Enter BLOWER CONFIGURATION menu (manager access) and turn Energy Mode to OFF. Oven will now run in BAKING mode all the time. Call service to schedule repair.
Baked product comes out underdone.	Photo eye not working. Check to see if BAKING appears on display when photo eye beam is interrupted	Enter BLOWER CONFIGURATION menu (manager access) and turn Energy Mode to OFF. Oven will now run in BAKING mode all the time. Call service to schedule repair.

B. ALERTS, ERRORS & REMEDIES

SYMPTOM	PROBABLE CAUSE	REMEDY
PROBE 1 OPEN on display and audible alarm sounds.	Temperature Probe number 1 (upper left) is open.	Press enter key  to silence alarm and resume operation. Control will compensate for lost probe. Call service to repair.
FRONT BELT STALLED FRONT BELT STALLED shown on display and audible alarm sounds.	Belt was overloaded and control shut down the belt.	Press  to silence alarm. Check belt for cause of jamming and follow screen instructions to resume belt operation.
FRONT BELT COMM LOST or BACK BELT COMM LOST shown on display and audible alarm sounds.	Circuit breaker to conveyor motor drive board is tripped. Oven will continue operation with single belt in operation.	Press  to silence alarm. Clear any obstructions to belt travel and reset 1A breaker. If unsuccessful, call for service.
UPR SW NOT CLOSED or LWR SW NOT CLOSED shown on display and audible alarm sounds	Switch proving that the blowers are operating is not closed. Error caused either by switch itself or by one or more blowers not operating.	Press enter key  to silence alarm. Unplug oven and plug in again. Restart oven. If unsuccessful, call service for immediate repair.
HEATING ERROR shown on display and audible alarm sounds.	The oven has failed to preheat in the expected time period (30 minutes). Either a burner issue is occurring, or the oven was interrupted while heating up.	Press enter key  to silence alarm. Turn oven off and back on again. If unsuccessful and error reoccurs, call for service.
PROBES OPEN shown on display and audible alarm sounds	All thermocouple probes have failed and are open.	Press enter key  to silence alarm. Call service for immediate repair.
I/O COMM LOST	Communication between the display (user interface) and the I/O board has occurred.	Press enter key  to silence alarm. Call service for immediate repair.
“IGNITION LOCKOUT” on display	Oven burner failed to light / stay lit 1. Gas not turned on to oven 2. Burner has stopped running	Press enter key  to silence alarm. Turn the oven off and back on again to clear the notification and relight.

NOTE: If the remedial measures above do not successfully resolve the issue, or the issue is not listed above, contact the Middleby Customer Care Center at 847-429-7852.

SECTION 4 - MAINTENANCE

WARNING

Before ANY cleaning or servicing of the oven, perform the following procedure:

1. Switch off the oven and allow it to cool. Do NOT service the oven while it is warm.
2. Turn off the electric supply circuit breaker(s) and disconnect the electric supply to the oven.
3. If it is necessary to move a gas oven for cleaning or servicing, disconnect the gas supply before moving the oven.

When all cleaning and servicing is complete:

1. If the oven was moved for servicing, return the oven to its original location.
2. If the restraint cable was disconnected to clean or service the oven, reconnect it at this time.
3. Reconnect the gas supply.
4. Reconnect the electrical supply.
5. Turn on the full-flow gas safety valve. Test the gas line connections for leaks using approved leak test substance or thick soap suds.
6. Turn on the electric supply circuit breaker(s).
7. Perform the normal startup procedure.

WARNING

Possibility of injury from moving parts and electrical shock exists in this oven. Switch off and lockout/tagout the electric supply BEFORE beginning to disassemble, clean, or service any oven. Never disassemble or clean an oven with the BLOWER () switch or any other circuit of the oven switched on.

CAUTION

NEVER use a water hose or pressurized steam-cleaning equipment when cleaning this oven. To avoid saturating the oven insulation, DO NOT use excessive amounts of water. DO NOT use a caustic oven cleaner, which can damage the bake chamber surfaces.

NOTE

ANY replacement parts that require access to the interior of the oven may ONLY be replaced by a Middleby Marshall Authorized Service Agent. It is also strongly recommended that the 3-Month Maintenance and 6-Month Maintenance procedures in this section be performed ONLY by a Middleby Marshall Authorized Service Agent.

I. MAINTENANCE – DAILY

- A. Check that the oven is cool and the power is disconnected, as described in the warning at the beginning of this section.
- B. Clean ALL of the cooling fan grills and vent openings with a stiff nylon brush. Refer to Figure 4-1 for the location of the grills and vents
- C. Clean the outside of the oven with a soft cloth and mild detergent.
- D. Check that all cooling fans are operating properly.

CAUTION: If a cooling fan is not operating correctly, it must be replaced IMMEDIATELY. Operating the oven without adequate cooling can seriously damage the oven's internal components

- E. Clean the conveyor belts with a stiff nylon brush. This is more easily accomplished by allowing the conveyor to run while you stand at the exit end of the conveyor, and brush the crumbs off the conveyor as it moves.
- F. Remove and clean the crumb trays. If necessary, refer to Figure 2-16(in Section 2, Installation) when replacing the crumb trays into the oven.
- G. Clean the window in place.

Figure 4-1. Cooling Vents and Grills

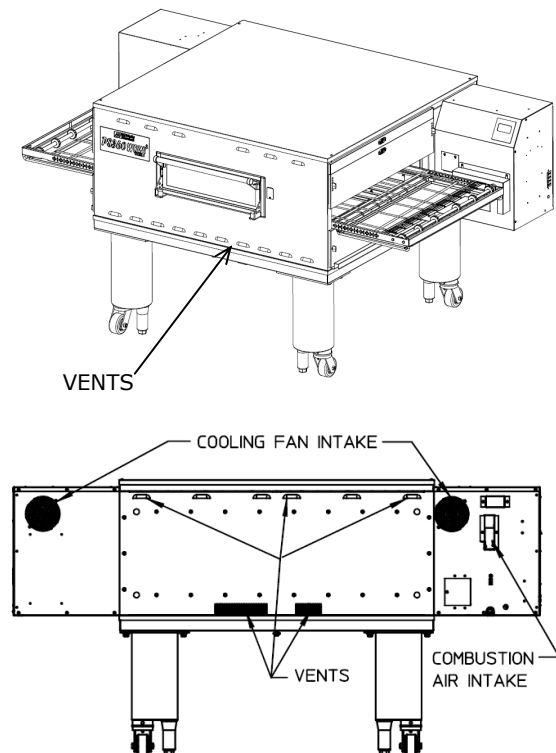

II. MAINTENANCE – MONTHLY

NOTE: When removing the conveyor, refer to Figure 2-12 (in Section 2, Installation).

- A. Check that the oven is cool and the power is disconnected as described in the warning at the beginning of this section.
- B. Remove the crumb trays from the oven.
- C. Lift the drive end of the conveyor slightly, and push it forward into the oven. This removes the tension from the drive chain. Remove the drive chain from the conveyor sprocket.
- D. Slide the conveyor out of the oven, folding at as it is removed.
- E. Remove the end plugs from the oven. The end plugs are shown in Figure 1-1 (in Section 1, Description).
- F. Slide the air fingers and blank plates out of the oven, as shown in Figure 4-2. AS EACH FINGER OR PLATE IS REMOVED, WRITE A “LOCATION CODE” ON IT WITH A MARKER to make sure it can be reinstalled correctly.

Example of markings:

Top Row → **T1** **T2** **T3** **T4**
 Bottom Row → **B1** **B2** **B3** **B4**

- G. Disassemble the air fingers as shown in Figure 4-3. AS EACH FINGER IS DISASSEMBLED, WRITE THE “LOCATION CODE” FOR THE FINGER ON ALL THREE OF ITS PIECES. This will help you in correctly reassembling the air fingers.

CAUTION: *Incorrect reassembly of the air fingers will change the baking properties of the oven.*



- H. Clean the air finger components and the interior of the baking chamber using a vacuum cleaner and a damp cloth. Refer to the boxed warnings at the beginning of this Section for cleaning precautions.
- I. Reassemble the air fingers. Then replace them in the oven, using the “location codes” as a guide.
- J. Replace the end plugs on the oven.
- K. Reassemble the conveyor into the oven. If the drive sprocket was removed when installing the conveyor, replace it at this time.
- L. Reattach the drive chain.
- M. Check the tension of the conveyor belt as shown in Figure 2-14 (in Section 2, Installation). The belt should lift between 3 and 4” (75-100mm) DO NOT OVERTIGHTEN THE CONVEYOR BELT. If necessary, the belt tension can be adjusted by turning the conveyor adjustment screws, located at the idler (left) end of the conveyor
- N. Replace the crumb trays.

Figure 4-2. Removing Air Fingers and Plates

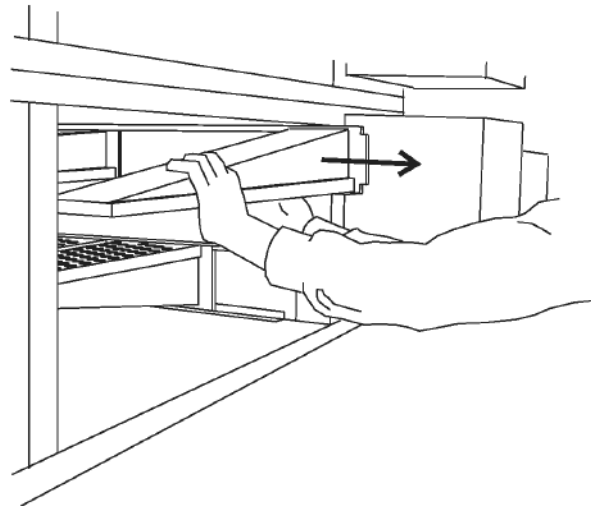
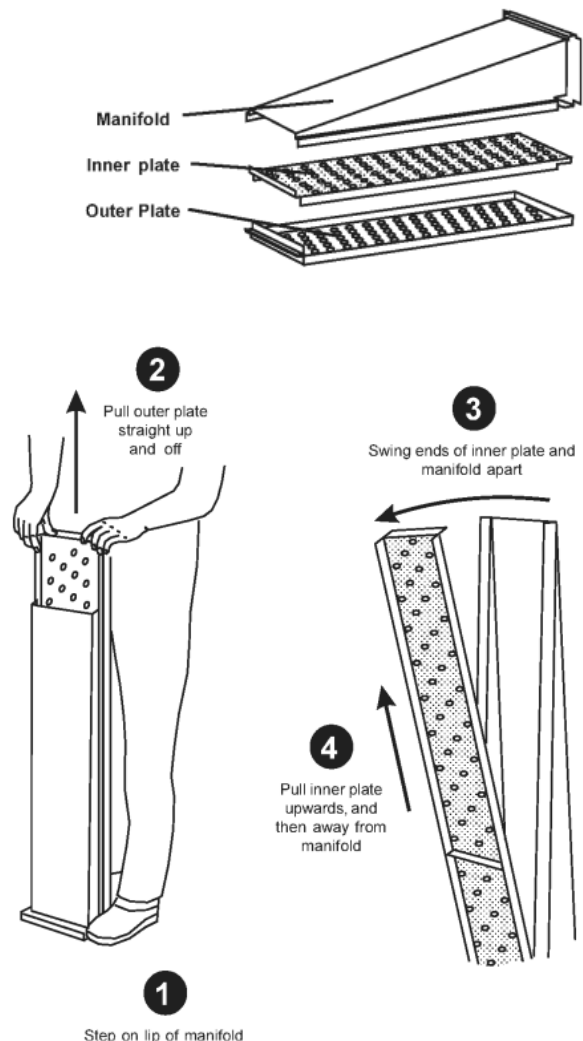

Figure 4-3. Disassembling the Air Fingers



III. MAINTENANCE – EVERY 3 MONTHS

A. Check that the oven is cool and the power is disconnected, as described in the warning at the beginning of this Section.

B. Vacuum both of the blower mounts, and their surrounding compartments, using a shop vacuum.

C. Tighten all electrical terminal screws.

D. Split Belt Disassembly and Cleaning

1. Refer to Part D, Conveyor Installation, in the Installation section of this Manual. Then, remove the following components from the oven:
 - Conveyor end stop
 - Crumb trays
 - Chain cover
 - Drive chains
 - End plugs
 - Conveyor assembly
2. Remove the master links from each conveyor belt. Then, roll the belts up along the length of the conveyor to remove them from the frame.
3. Remove the two conveyor adjustment screws from the idler end of the conveyor frame, as shown in Figure 4-4.
4. Remove the idler shaft assembly from the conveyor.
5. Pull apart the two sections of the idler shaft.
6. Clean the shafts thoroughly using a rag. Then, lubricate both the extended shaft and the interior of the hollow shaft using a light food-grade lubricant. DO NOT lubricate the shafts using WD40 or a similar product. This can cause the shafts to wear rapidly.
7. Before reassembling the shafts into the conveyor frame, check that they are oriented properly.

Figure 4-4. Disassembling the idler shaft

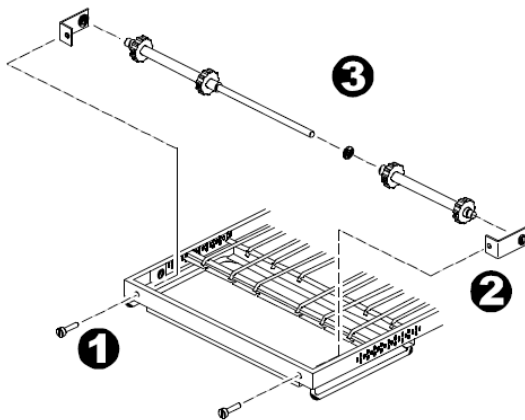

8. Reassemble the idler shaft into the conveyor. Make sure that the bronze washer is in place between the two sections of the shaft. See Figure 4-4.
9. Replace the conveyor adjustment screws as shown in Figure 4-4. To allow the conveyor belt to be reinstalled later, do not tighten the screws at this time.
10. Loosen the set screw on both of the conveyor drive sprockets. Then, remove the sprockets from the shaft.
11. Check the conveyor configuration as follows: High-speed conveyors are equipped with large flange bearings at both ends of the shaft, as shown in Figure 4-5. For these conveyors, remove the two screws that hold each bearing to the conveyor frame. With the screws removed, lift the end of the shaft at the front of the oven, and pull the entire assembly free of the conveyor frame.
12. Standard conveyors are equipped with bronze bushings mounted on spacers at both ends of the shaft, as shown in Figure 4-5. For these conveyors, remove the two screws that hold the bracket to the conveyor frame. With the screws removed, lift the end of the shaft at the front of the oven, and pull the entire assembly free of the conveyor frame. The brackets will be removed along with the drive shaft assembly.
13. Disassemble and lubricate the two sections of the drive shaft as described for the idler shaft, above.
14. Before reassembling the shafts into the conveyor frame, check that they are oriented properly.
15. Reassemble the drive shaft into the conveyor. Make sure that the bronze washer is in place between the two sections of the shaft. See Figure 4-4.
16. Replace the drive sprockets. Reassemble the belts and master links onto the conveyor.
17. Reinstall the end plugs and conveyor onto the oven. Reattach the drive chains. Replace the chain cover.
18. Check the tension of the conveyor belt as shown in Figure 2-14 (in Section 2, Installation). The belt should lift about 13 (25mm). If necessary, adjust the belt tension by turning the conveyor adjustment screws.
19. Replace all components onto the oven.

Figure 4-5. Drive shaft configurations

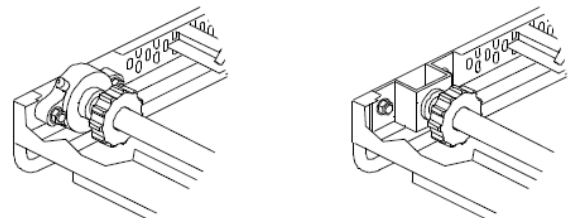
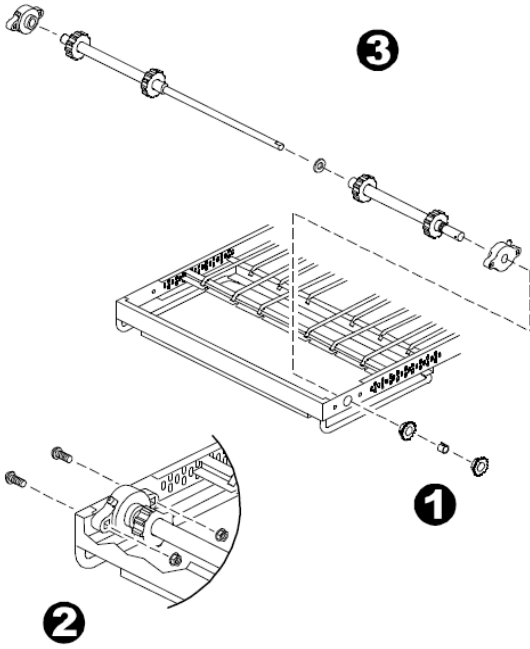

Figure 4-6. Disassembling the drive shaft



IV. MAINTENANCE - EVERY 6 MONTHS

A. Check that the oven is cool and the power is disconnected, as described in the warning at the beginning of this Section.

C. For gas ovens, inspect and clean the burner nozzle and the spark electrode assembly.

D. Check the conveyor drive shaft bushings and spacers. Replace the components if they are worn.

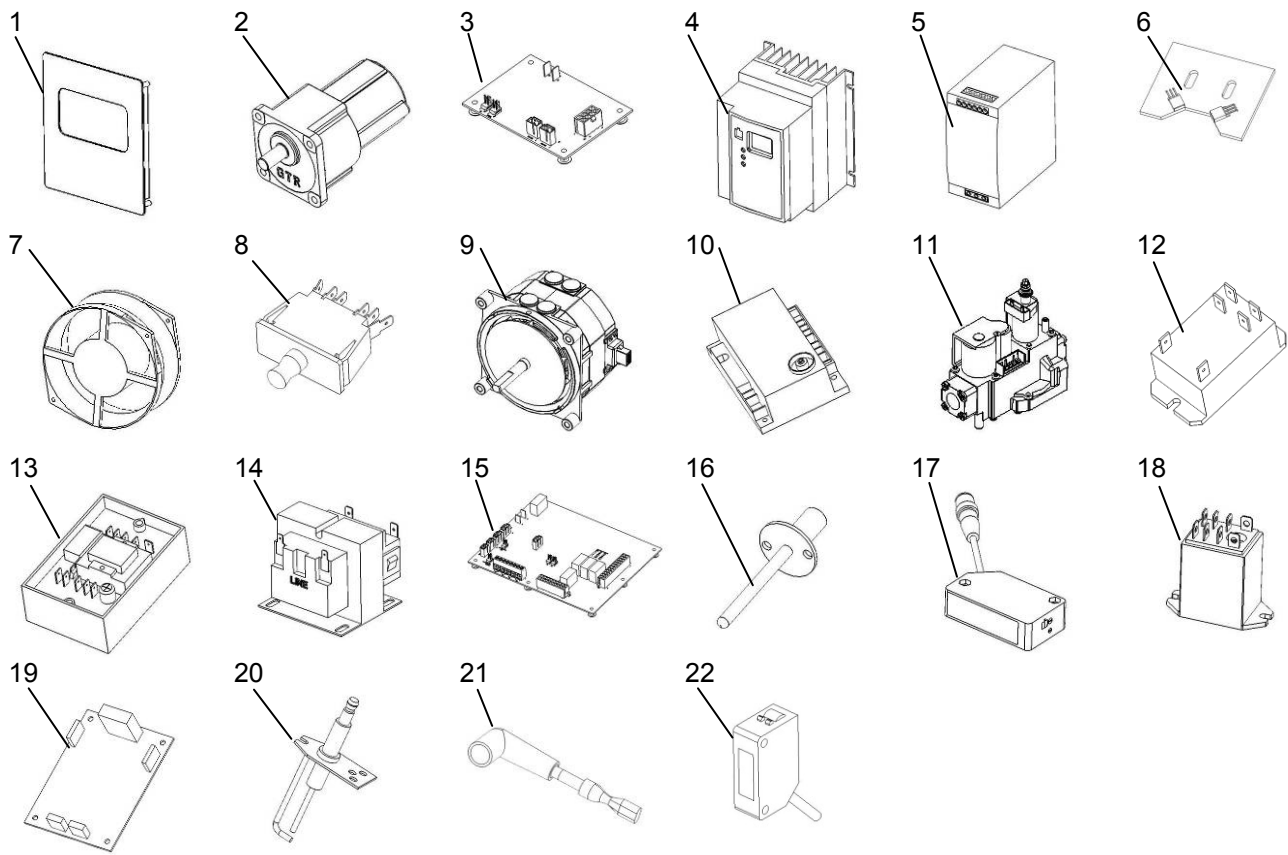

KEY SPARE PARTS PS360G GAS OVEN

ITEM	QTY	P/N	DESCRIPTION
1	1	65564	Digital Display, Programmed
2	1	65756	Motor, Conveyor Drive
3	1	65566	Conveyor Control Board
4	1	69614	Inverter, 2 HP Lenze (230V Input)
5	1	69079	Power Supply, 24VDC, 120W
6	1	69583	Rotation Sensor (1 per motor)
7	1	36451	Fan,Cooling
8	2	63909	Switch, Door Interlock
9	1	69149	Blower Motor, 1/3 HP
10	1	61602	Ignition Module
11	1	60679	Gas Valve (Modulating) w/ flanges and cable
12	1	50794	Relay, 30A (240V coil)
13	1	33983	Hi Limit Thermostat
14	1	32108	Transformer, 240 primary / 24 secondary
15	1	65565	Board,Main – I/O
16	2	60520-2	Thermocouple, 2" Grounded (4 per oven)
17	1	60185	Photo Sensor
18	1	59132	Relay, DPDT 24VDC Coil
19	2	69582	Rotation Switch Board
20	1	62288	Igniter, Single Rod
21	1	62282	Ignition Cable
22	1	69472	Front Photo Eye (optional)

SECTION 5 - WIRING DIAGRAMS

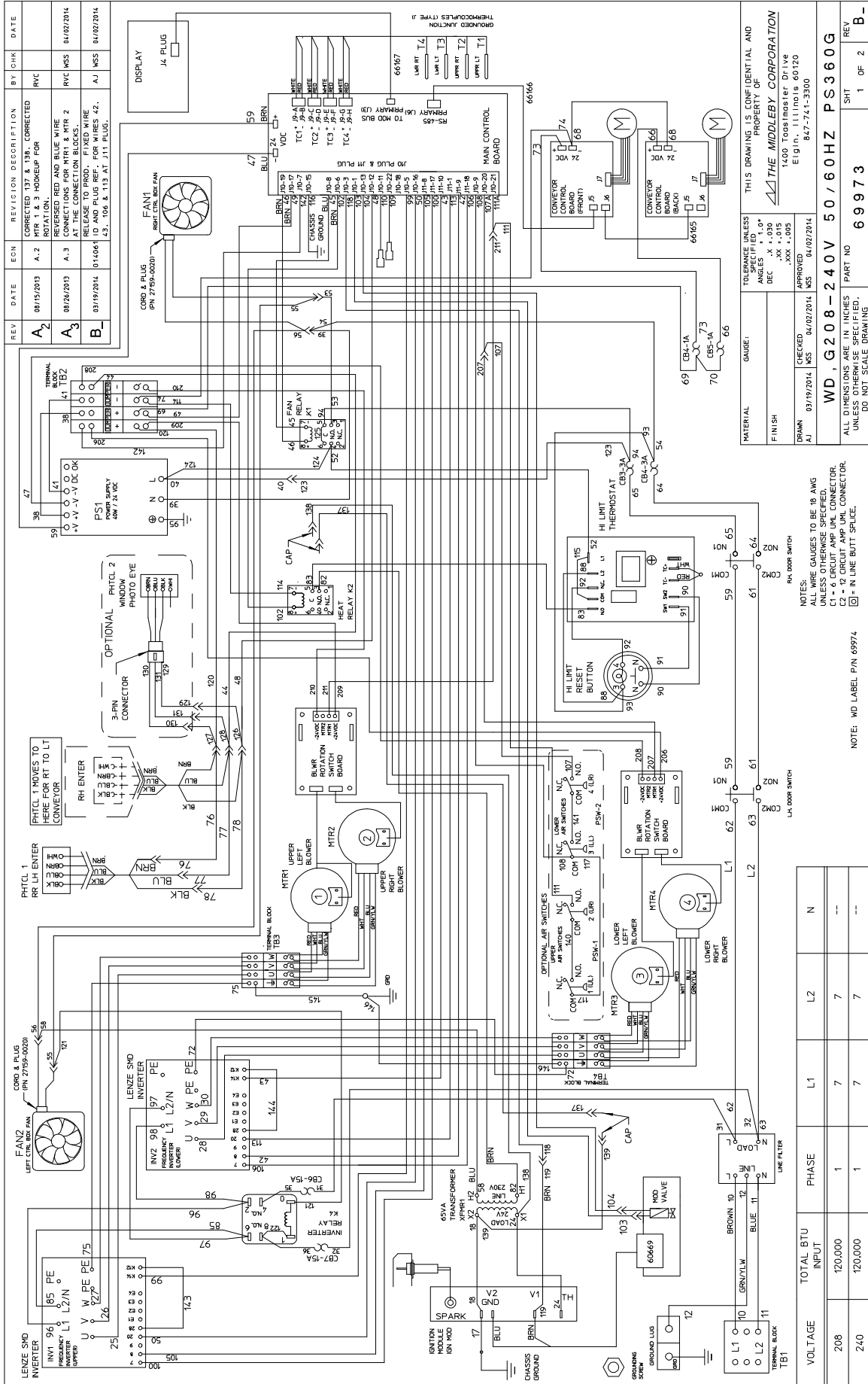

REV	DATE	ECN	REVISION DESCRIPTION	BY	CHK	DATE
A2	09/15/2013	A.2	CORRECTED 137 & 138. CORRECTED RTR 1 & 3 HOKEUP FOR ROTATION.	RVC		
A3	08/26/2013	A.3	REVERSED RED AND BLUE WIRE CONNECTIONS AT RTR 2 AT THE CONNECTION BLOCKS.	RVC		01/02/2014
B	03/19/2014	014065	RELEASE TO PROD. FIXED WIRE ID AND PLUG REF. FOR WIRES 42, 43, 106 & 113 AT J11 PLUG.	AJ	WSS	01/02/2014

MATERIAL		GAUGE:		TOLERANCE UNLESS SPECIFIED:	
FINISH		ANGLES		DEC .X .030	
DRAWN		CHECKED		APPROVED:	
AJ		WSS		WSS	
DATE		DATE		DATE	
03/19/2014		04/02/2014		04/02/2014	
PART NO		PART NO		PART NO	
WD, G208-240V		50/60HZ		PS360G	
SHT		SHT		SHT	
1		1		1	
OF		OF		OF	
2		2		2	
REV		REV		REV	
B		B		B	

THIS DRAWING IS CONFIDENTIAL AND PROPERTY OF THE MIDDLEBY CORPORATION
 1400 Toombs Street Drive
 Elgin, IL 60120
 847-741-3300

NOTE: WIRE GAUGES TO BE 18 AWG ALLEN BRADLEY C1 - 6 CIRCUIT AMP UNL CONNECTOR, C2 - 12 CIRCUIT AMP UNL CONNECTOR. □ = IN LINE BUTT SPICE.

NOTE: MD LABEL P/N 69974

VOLTAGE	TOTAL BTU INPUT	PHASE	L1	L2	N
208	120,000	1	7	7	--
240	120,000	1	7	7	--

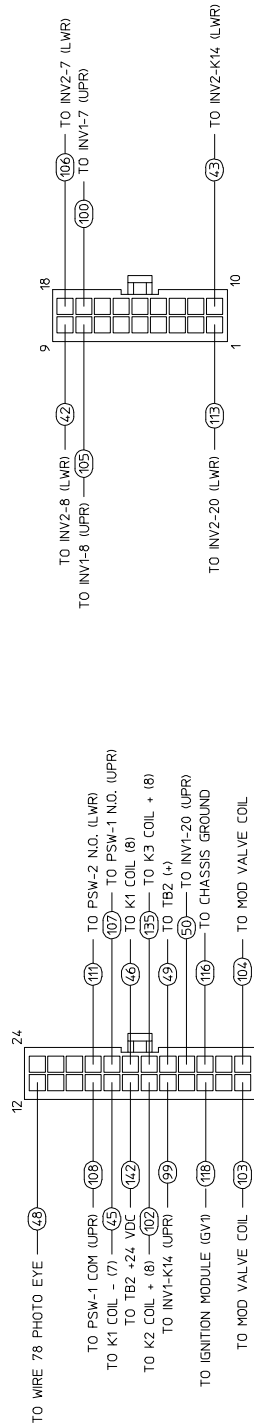

J10
BACK OF PLUG
(WIRE SIDE)

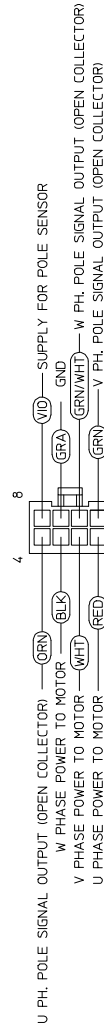

J7
BACK OF PLUG
(WIRE SIDE)
BROTHER YGKC10

TOLERANCE UNLESS SPECIFIED ANGLES ± 1.0° DEC .XX ± .015 .XXX ± .005	APPROVED	DATE	BY
	MSS 04/02/2014	04/02/2014	04/02/2014
DRAWN / 03/19/2014			
PROPERTY OF THE MIDDLEBY CORPORATION			
1400 TROST INDUSTRIAL DRIVE E19117 847-241-3300			
WD, G208-240V 50/60HZ PS360G		PART NO	REV
ALL DIMENSIONS ARE IN INCHES UNLESS OTHERWISE SPECIFIED. DO NOT SCALE DRAWING		69973	2 OF 2

NOTES

WARNING

Improper installation, adjustment, alteration, service or maintenance can cause property damage, injury or death. Read the installation, operating and maintenance instructions thoroughly before installing or servicing this equipment.

NOTICE

During the warranty period, ALL parts replacement and servicing should be performed by your Middleby Marshall Authorized Service Agent. Service that is performed by parties other than your Middleby Marshall Authorized Service Agent may void your warranty.

NOTICE

Using any parts other than genuine Middleby Marshall factory manufactured parts relieves the manufacturer of all warranty and liability.

NOTICE

Middleby Marshall reserves the right to change specifications at any time.

CFESA

Commercial Food Equipment Service Association

Middleby is proud to support the Commercial Food Equipment Service Association (CFESA). We recognize and applaud CFESA's ongoing efforts to improve the quality of technical service in the industry.

Middleby Cooking Systems Group • 1400 Toastmaster Drive • Elgin, IL 60120 • USA • (847)741-3300 • FAX (847)741-4406

www.middleby.com

