



# MODEL MT3240E/G Gas/Electric Conveyor Oven



Project \_\_\_\_\_

Item No. \_\_\_\_\_

Quantity \_\_\_\_\_

MT3240E/G

Blodgett conveyor oven with 32" (813mm) wide belt and 40" (1016mm) baking zone length. Single, double or triple stack models are available. All data is shown per oven section, unless otherwise indicated.

### EXTERIOR CONSTRUCTION

- Stainless steel front, top and sides
- Aluminized steel back and bottom
- Front loading solid stainless steel door and handle
- 1-1/2" (38.1mm) Vitreous fiber insulation at bottom, back and top
- Ceramic fiber insulation at blower installation

### INTERIOR CONSTRUCTION

- Aluminized steel nozzles and bottom surface
- Aluminized steel air flow plates at top
- 32" (813mm) stainless steel wire mesh conveyor belt
- Two single inlet blowers above the combustion or heater area for air circulation

### OPERATION

- Heat transferred through forced air convection
- Open vented baking compartment
- Electronic spark ignition control system (gas model)
- Gas power type burner has mixer with adjustable shutter and sight window (gas model)
- Internal gas pressure regulator (gas model)
- Tubular resistance heat (electric model)
- Integral or remote microprocessor based controls with solid state 600°F (315.5°C) maximum thermostat and belt speed control with digital display
- Two blower motors (1/8 HP minimum) with thermal overload protectors
- Four blower area cooling fans

### STANDARD FEATURES

- Control options: *(must specify)*
  - computerized end mounted       computerized remote
- Belt direction: *(must specify)*
  - left to right       right to left
- 23-1/2" (595mm) black legs with casters - for single model
- 17-1/2" (445mm) black legs with casters - for double model
- Triple stack base with casters - for triple model
- Product stops
- Oven start-up\*
- One year parts & labor warranty\*

\* For all international markets, contact your local distributor.

### OPTIONS AND ACCESSORIES (AT ADDITIONAL CHARGE)

- 15" (381mm) shelf extension
- 20" (508mm) shelf extension
- Twin belt - two 16" (406mm) wide belts
- Stainless steel interior
- 10' (3.0M) cord with receptacle (gas model only) (w/remote control only)
- 48" (1219mm) flexible gas hose with quick disconnect and restraining device
- 36" (914mm) flexible gas hose with quick disconnect and restraining device

*Note: Two 48" (1219mm) and one 36" (914mm) hose on triple model*

- One year additional extended warranty\*



**BLODGETT OVEN COMPANY**  
 50 Lakeside Avenue, Burlington, VT 05402  
 Toll Free: (800) 331-5842 • Phone: (802) 860-3700 • Fax: (802) 864-0183



COMMERCIAL SOLUTIONS

# MODEL MT3240E/G

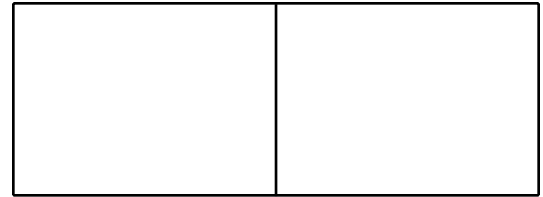

APPROVAL/STAMP

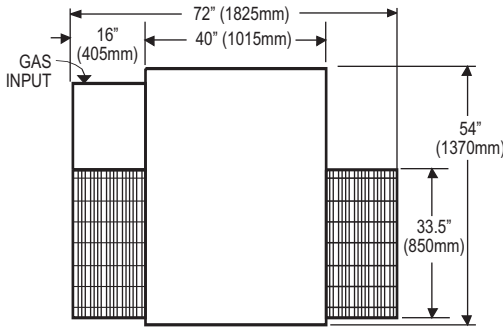

TOP VIEW

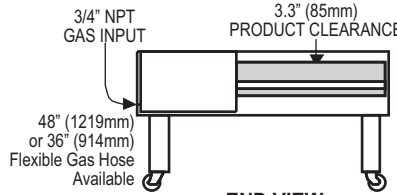

END VIEW

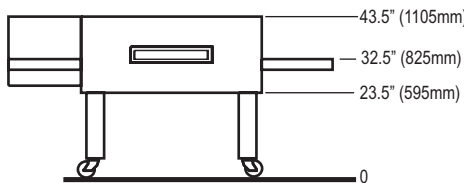

SIDE VIEW

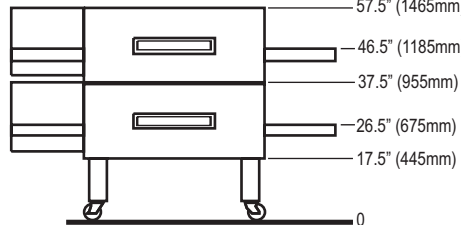

SIDE VIEW

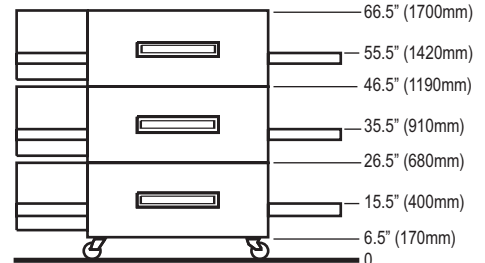

SIDE VIEW

**SHORT FORM SPECIFICATIONS**

Provide Blodgett conveyor model MT3240(G/E) conveyor oven. Unit shall be (gas fired/electrically heated) and shall cook by means of forced, heated air. Unit shall be (single/double/triple) deck supported by (specify stand type from options list). Each deck shall be fully independent, of stainless steel construction, and fully insulated on all sides. Provide with (electronic spark ignition gas fired/electrically heated) baking compartment with two blowers to evenly distribute heat across baking zone. Conveyor belt shall be 32" (815mm) wide and constructed of stainless steel wire mesh; baking zone length shall be 40" (1015mm). Unit shall be provided with solid stainless steel side loading door. (End mounted/remote) control panel shall be solid state with 600°F (315.5°C) maximum thermostat and digital display of adjustable belt speed. Provide start-up inspection service by a factory authorized service agent. Provide options and accessories as indicated.

**DIMENSIONS:**

<b>Floor space</b>	54" (1370mm) W x 72" (1825mm) L
<b>Product clearance</b>	3.3" (85mm)
<b>Combustible wall clearance</b>	2" (50mm) gas and electric
<b>Belt width</b>	
Standard belt	32" (815mm)
Optional twin belt	16" (405mm) each
<b>Baking zone length</b>	40" (1015mm)

**POWER SUPPLY** (must have dedicated ground)

**MT3240E**

V.A.C.	Hz	Phase	K.W.H.	Amperes				N
				L1	L2	L3		
DOMESTIC								
208	60	3	24	67	67	67	-	
240	60	3	24	58	58	58	-	
INTERNATIONAL								
220/380	50	3N	24	39	39	39	-	
240/415	50	3N	24	34	34	34	-	
CE MODEL								
230/400	50	3N	24	33	33	33	-	

This oven contains a mercury relay. DO NOT put mercury relay in trash. Relay must be recycled or disposed of as hazardous waste.

**MT3240G**

DOMESTIC

3-wire with Neutral, 5 amp. 120/208-240 VAC, 1 phase, 60 Hz.

INTERNATIONAL

4 amp. 220/240 VAC, 1 phase, 50 Hz, 2 wire with ground

**NOTE:** The company reserves the right to make substitutions of components without prior notice

Printed in U.S.A.

**GAS SUPPLY: (specify)**

	Natural	Propane
Single	3/4" NPT	3/4" NPT
Double stack	1" NPT	3/4" NPT
Triple stack	1" NPT	1" NPT

**MAXIMUM INPUT:**

	MT3240G	MT3240E
Single	100,000 BTU/hr	24 KW
Double	200,000 BTU/hr	48 KW
Triple	300,000 BTU/hr	72 KW

**Minimum Gas Pressure:** 4.5" W.C. for natural gas  
11.0" W.C. for propane gas

**Maximum Gas Pressure:** 10.5" W.C. for natural gas  
13" W.C. for propane gas

**MINIMUM ENTRY CLEARANCE:**

Uncrated	21" (533mm)
Crated	32" (813mm)

**SHIPPING INFORMATION:**

Approx. Weight:	Crated	Uncrated
Single	850 lbs. (385 kg)	750 lbs. (340 kg)
Double	1700 lbs. (770 kg)	1500 lbs. (680 kg)
Triple	2550 lbs. (1155 kg)	2250 lbs. (1020 kg)

**Crate sizes:**

32" (813mm) x 70" (1778mm) x 105" (2667mm)

**BLODGETT OVEN COMPANY**

50 Lakeside Avenue, Burlington, VT 05402

Toll Free: (800) 331-5842 • Phone: (802) 860-3700 • Fax: (802) 864-0183

**NOTE:** FOR COMMERCIAL USE ONLY

P/N M9991 Rev D (4/00)