



MT1828G

MODEL MT1828G Gas Conveyor Oven



Project _____

Item No. _____

Quantity _____

BLODGETT conveyor oven with 18" (457mm) wide belt and 28" (711mm) baking zone length. Single, double or triple stack models. Base units available for stacking with existing oven.

All data is shown per oven section, unless otherwise indicated.

EXTERIOR CONSTRUCTION

- Stainless steel front, top and sides
- Aluminized steel back and bottom
- 2" (51mm) Vitreous fiber insulation at bottom, back and top
- Ceramic fiber insulation at blower installation

INTERIOR CONSTRUCTION

- Aluminized steel nozzles and bottom surface
- Adjustable aluminized steel air flow plate at top
- 18" (457mm) stainless steel wire mesh conveyor belt
- Two single inlet blowers above the combustion area for air circulation

OPERATION

- Heat transferred through forced convection (impinging)
- Open vented baking compartment
- Direct spark ignition system
- Integral or remote microprocessor based controls with solid state 600°F (315.5°C) maximum thermostat and belt speed control with digital display
- Two blower motors (1/8 HP minimum) with thermal overload protectors
- Four blower area cooling fans
- Internal gas pressure regulator
- Gas power burner

STANDARD FEATURES

- Computerized end mounted controls
- Belt direction: (must specify)
 - left to right right to left
- Product stops
- 24" (610mm) stand with casters
- Oven start-up
- Removable single unit belt assembly
- One year parts & labor warranty*

* For all international markets, contact your local distributor.

OPTIONS AND ACCESSORIES

(AT ADDITIONAL CHARGE)

- Flexible gas hose with quick disconnect and restraining device:
 - 36" (914mm)
 - 48" (1219mm)

Note: Two 48" (1219mm) and one 36" (914mm) hose on triple model

- Triple stack base with casters
- 12" (304mm) Shelf extension
- Side loading glass door
- 10' (3.0M) cord with receptacle
- One year additional extended warranty

OPTIONS AND ACCESSORIES

(AT NO ADDITIONAL CHARGE)

- Remote computerized control



BLODGETT OVEN COMPANY

www.blodgett.com

50 Lakeside Avenue, Burlington, VT 05402

Toll Free: (800) 331-5842 • Phone: (802) 860-3700 • Fax: (802) 864-0183



MODEL MT1828G

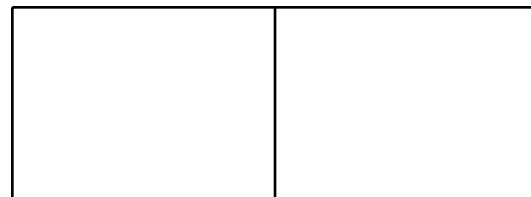

APPROVAL/STAMP

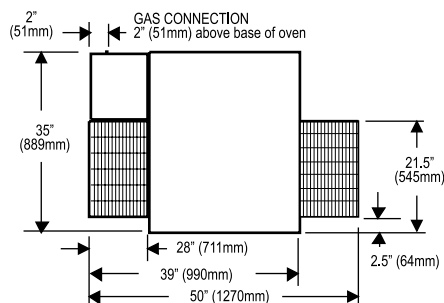

TOP VIEW

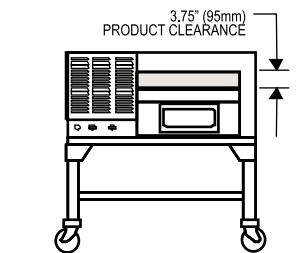

END VIEW

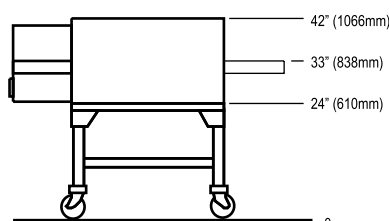

SIDE VIEW

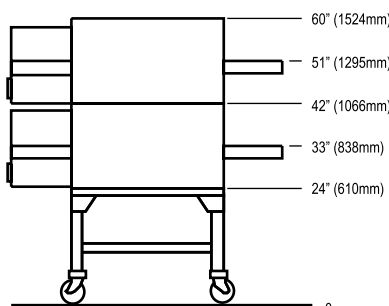

SIDE VIEW

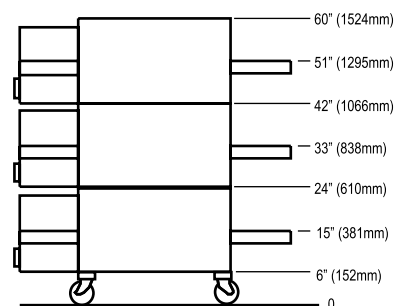

SIDE VIEW

SHORT FORM SPECIFICATIONS

Provide Blodgett conveyor model MT1828G conveyor oven. Unit shall be gas heated and shall cook by means of forced, heated air. Unit shall be (single/double/triple) deck supported by (specify stand type from options list). Each deck shall be fully independent, of stainless steel construction, and fully insulated on all sides. Provide with gas heated baking compartment with two blowers to evenly distribute heat across baking zone. Conveyor belt shall be 18" (457mm) wide and constructed of stainless steel wire mesh; baking zone length shall be 28" (711mm). Side mounted control panel shall be solid state with 600°F (315.5°C) maximum thermostat and digital display of adjustable belt speed. Provide start-up inspection service by a factory authorized service agent. Provide options and accessories as indicated.

DIMENSIONS:

Floor space: 35" (889mm) wide x 50" (1270mm) long
 Product clearance: 3.75" (95.25mm)
 Belt width: 18" (457mm)
 Baking zone length: 28" (711mm)

GAS SUPPLY (specify): Natural Propane
 Single 3/4" NPT 3/4" NPT
 Double stack 3/4" NPT 3/4" NPT
 Triple stack 3/4" NPT 3/4" NPT

MAXIMUM INPUT (BTU/hr):

MT1828G
 Single: 40,000
 Double stack: 80,000
 Triple Stack: 120,000

Gas Pressures:

Minimum 4.5" W.C. for natural gas or propane
 Maximum 10.5" W.C. for natural gas or propane
 CE Minimum 4.5" W.C. for natural gas 11.0" W.C. for propane gas
 CE Maximum 10.5" W.C. for natural gas 13.0" W.C. for propane gas

POWER SUPPLY: (with dedicated ground)

Domestic Model:
 120/208-240 VAC, 1 Phase, 60 Hz, 5 amp, 3 wire with ground
Export Model:
 220-240 VAC, 1 Phase, 50 Hz., 5 amp, 2 wire with ground

MINIMUM ENTRY CLEARANCE:

Uncrated 18" (457mm)
 Crated 25" (635mm)

COMBUSTIBLE WALL CLEARANCE:

Gas 0"

SHIPPING INFORMATION:

Approx. Weight: Crated Uncrated*
 Single: 450 lbs. (204 kg) 320 lbs. (145 kg)
 Double stack: 900 lbs. (407 kg) 640 lbs. (291 kg)
 Triple stack: 1350 lbs. (611 kg) 960 lbs. (436 kg)

*Add: 140 lbs. (64 kg) when ordered with stand and frame.

Crate sizes:

23-1/4" (591mm) x 54-1/2" (1384mm) x 58" (1473mm)

NOTE: The company reserves the right to make substitutions of components without prior notice

BLODGETT OVEN COMPANY

www.blodgett.com

50 Lakeside Avenue, Burlington, VT 05402

Toll Free: (800) 331-5842 • Phone: (802) 860-3700 • Fax: (802) 864-0183