



**BE3240
CONVEYOR OVEN
REPLACEMENT PARTS MANUAL
(with WIRING DIAGRAMS)**



EFFECTIVE with SERIAL #41341105 and AFTER

Serial # Code
First 4 digits - order of production
Fifth digit - model specific
Sixth and Seventh digit - month of production
Eighth and Ninth digit - year of production

Table of Contents: Page 2

BLODGETT CONVEYOR OVENS, 1400 Toastmaster Drive, Elgin, IL 60120
Telephone: 847-741-3300 • Fax Number 847-741-4406

www.blodgett.com

email: techsupport@middleby.com

Table of Contents

Spec Sheet	3
Oven and Electrical Specifications	5
Standard Finger Configuration	6
Key Parts	7
View of Oven Panels, Window and Legs	8
Parts for Oven Panels, Window and Legs	9
View of Right-hand Control Compartment	10
Parts for Right-hand Control Compartment	11
View of Blower Area	12
Parts for Blower Area	13
View of Blower/Motor Compartment	14
Parts for Blower/Motor Compartment	15
View of "Single" Belt Conveyor	16
Parts for "Single" Belt Conveyor	17
View of "Split" Belt Conveyor	18
Parts for "Split" Belt Conveyor	19
SERIES BE3240 OVEN INSTALLATION KIT	20
Model BE3240 Single Oven Option Base Kit	21
Model BE3240 Double Oven Option Base Kit	22
Model BE3240 Triple Oven Option Base Kit (Outriggers)	23
Wiring Diagram, E208-240V 50/60 3PH 4W 50466 Rev. B2 US	24
Ladder Wiring Diagram, E208-240V 50/60 3PH 4W 50466 Rev. B1 US	25
Wiring Diagram, E380-480V 50/60 3PH 5W 50140 Rev. B2 US	26
Ladder Wiring Diagram, E380-480V 50/60 3PH 5W 50140 Rev. B1 US	27
Wiring Diagram, E380V 50/60/3CE 540 ENGLISH 50467 Rev. B2	28
Ladder Wiring Diagram, E380V 50/60/3CE 540 ENGLISH 50467 Rev. B1	29
Wiring Diagram, E400-416 50/60 3PH 5W 51068 Rev. C2	30
Ladder Wiring Diagram, E400-416 50/60 3PH 5W 51068 Rev. C1	31
Wiring Diagram, E380/50/60/3 5W CE 540 DN 51326 Rev. B	32
Wiring Diagram, E380/50/60/3 5W CE 540 DUT 51334 Rev. B	33
Wiring Diagram, E380/50/60/3 5W CE 540 FR 51318 Rev. B	34
Wiring Diagram, E380/50/60/3 5W CE 540 GM 51316 Rev. B	35
Wiring Diagram, E380/50/60/3 5W CE 540 GK 51336 Rev. B	36
Wiring Diagram, E380/50/60/3 5W CE 540 IT 51328 Rev. B	37
Wiring Diagram, E380/50/60/3 5W CE 540 SP 51324 Rev. B	38
Wiring Diagram, E380/50/60/3 5W CE 540 SW 51331 Rev. B	39



MODEL BE3240 & BG3240 Electric/Gas Conveyor Oven



OPTIONS AND ACCESSORIES

(AT ADDITIONAL CHARGE)

- Twin belt - two 15" (381mm) wide belts
- One year additional extended warranty*



Project _____

Item No. _____

Quantity _____

Blodgett conveyor oven with 32" (813mm) wide belt and 40" (1016mm) baking zone length. Single, double or triple stack models. Stacking kits available for stacking with existing SG3240 oven.

All data is shown per oven section, unless otherwise indicated.

EXTERIOR CONSTRUCTION

- Stainless steel front, top, bottom and sides
- Aluminized steel back
- Full drop down front window

INTERIOR CONSTRUCTION

- Stainless steel outer plates
- 32" (813mm) stainless steel wire mesh conveyor belt
- One single inlet blower in plenum for air circulation
- Upper and lower air fingers

OPERATION

- Heat transferred through forced convection (impinging)
- Open vented baking compartment
- Solid state digital controls to display set point and actual temperature as well as belt speed
- Electronic spark ignition control system (gas model)
- Gas power type burner has mixer with adjustable shutter and sight window (gas model)
- Internal gas pressure regulator (gas model)
- Tubular resistance elements (electric model)
- Solid state speed control with motor feedback
- Two circulation blower motors
- 3-30 minute bake time

STANDARD FEATURES

- Field reversible belt direction
- Large front loading door with window and stainless steel handle
- Product stop
- Cord set and plug (NEMA L6-15P) domestic gas ovens only
- Folding removable conveyor belt assembly
- Adjustable belt tensioning feature
- Flexible gas hose with quick disconnect and restraining device
- Oven start-up*
- One year parts & labor warranty*

* For all international markets, contact your local distributor.

BE3240 & BG3240

BLODGETT CONVEYOR OVEN

www.blodgett.com

1400 Toastmaster Drive, Elgin, IL 60120 • Phone: 847-741-3300 • Fax Number 847-741-4406



MODELS BE3240 & BG3240G

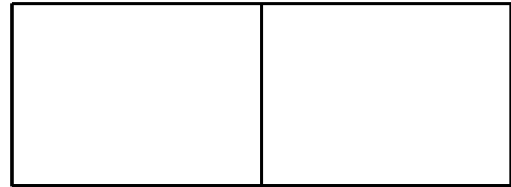

APPROVAL/STAMP

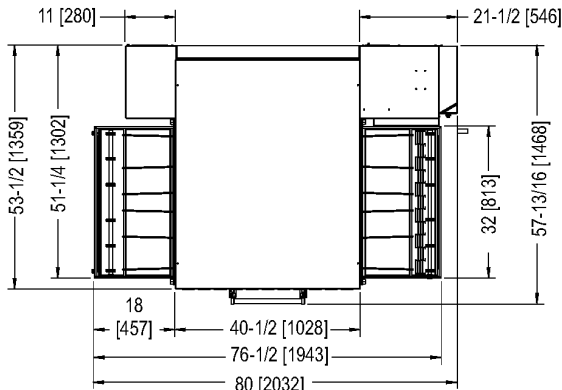

TOP VIEW

DIMENSIONS ARE IN INCHES [MM]

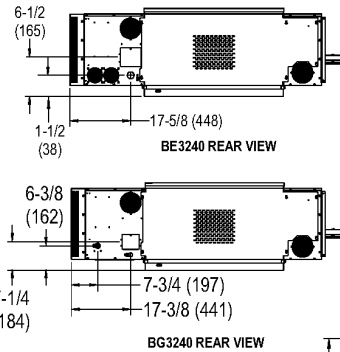

BG3240 REAR VIEW

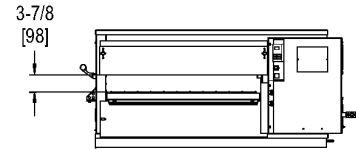

END VIEW

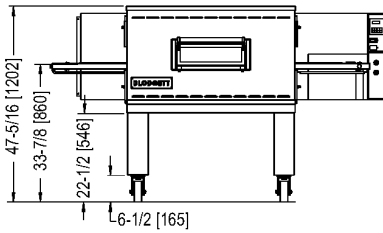

SINGLE

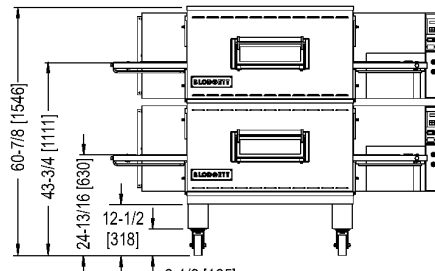

DOUBLE

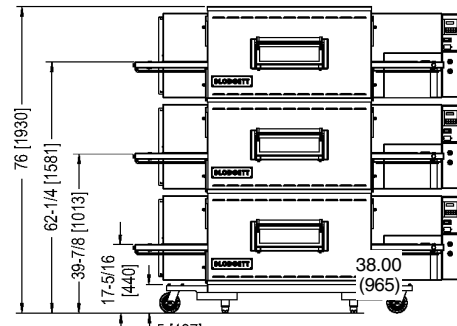

TRIPLE

SHORT FORM SPECIFICATIONS

Provide Blodgett conveyor model BE3240 (electric) or BG3240 (gas) conveyor oven. Unit shall cook by means of forced, heated air. Unit shall be (single/double/triple) deck. Each deck shall be fully independent, of stainless steel construction, and fully insulated on all sides. Provide with (electronic spark ignition gas fired/electrically heated) baking compartment with one blower to evenly distribute heat across baking zone. Conveyor belt shall be 32" (813mm) wide and constructed of stainless steel wire mesh; baking zone length shall be 40" (1016mm). Unit shall be provided with drop down front window. Control panel shall be solid state with 550°F (288°C) maximum thermostat and LCD display of 3-30 minutes adjustable belt speed. Provide start-up inspection service by a factory authorized service agent. Provide options and accessories as indicated.

DIMENSIONS:

Floor space	80" (2032mm) W x 60-1/2" (1537mm) L		
Product clearance	3-7/8" (98mm)		
Combustible wall clearance	Left	Right	Rear
BE3240	0" (0mm)	0" (0mm)	3" (76mm)
BG3240	3" (76mm)	18" (457mm)	3" (76mm)
Belt width			
Standard belt	32" (813mm)		
Optional twin belt	15" (381mm) each		
Baking zone length	40" (1016mm)		

MAXIMUM INPUT: (per section)

BE3240	27 kW
BG3240	120,000 BTU/hr (35 KW) (126.5 MJ/hr)

GAS SUPPLY: (specify)

	Natural	Propane
Oven per cavity	1/2" NPT	3/4" NPT
Main gas supply	2" line	1-3/8" line
Minimum Gas Pressure:	6" W.C.	11.0" W.C.
Maximum Gas Pressure:	12" W.C.	14" W.C.

POWER SUPPLY (must have dedicated ground)

BE3240	
Domestic	208 VAC, 50/60 hz, 3 ph, 75 amp, 3-wire plus ground 240 VAC, 50/60 hz, 3 ph, 65 amp, 3-wire plus ground
International	380 VAC, 50/60 hz, 3 ph, 41 amp, 3-wire plus N and ground 480 VAC, 50/60 hz, 3 ph, 32.5 amp, 3-wire plus N and ground
CE	380 VAC, 50 hz, 3 ph, 41 amp, 3-wire plus N and ground
BG3240	
Domestic	208-240 VAC, 1 phase, 50/60 Hz., 4.1 amp., 2-wire plus ground
International	220-230 VAC, 1 phase, 50 Hz., 4.1 amp., 2-wire plus ground

MINIMUM ENTRY CLEARANCE:

Uncrated 25-3/4" (654mm)

SHIPPING INFORMATION:

Approx. Weight:	
Single	1100 lbs. (499 kg)
Double	2200 lbs. (999 kg)
Triple	3300 lbs. (1498 kg)

NOTE: The company reserves the right to make substitutions of components without prior notice

BLODGETT CONVEYOR OVEN

www.blodgett.com

1400 Toastmaster Drive, Elgin, IL 60120 • Phone: 847-741-3300 • Fax Number 847-741-4406

NOTE: FOR COMMERCIAL USE ONLY

BE3240 SERIES OVEN SPECIFICATIONS

Conveyor Belt Width	32" (813mm)
Heating Zone Length	40-1/2" (1028mm)
Baking Area Square Feet	9 sq. ft. (0.84 sq. m.)
Overall Dimension Standard Single Oven w/Legs	80" (2032mm) L x 61-5/16" (1557mm) W x 47-5/16" (1202mm) H x
Overall Dimension Double Oven	80" (2032mm) L x 61-5/16" (1557mm) W x 60-15/16" (1548mm) H x
Overall Dimension Triple Oven	80" (2032mm) L x 61-5/16" (1557mm) W x 77-1/2" (1969mm) H x
Weight of Single Oven	925 lb (419kg)
Shipping Weight	1,100 lb (498.3kg)
Shipping Cube	Approx. 132 ft ³ (3.74 m ³)
Operating Range	27 kW/hr
Maximum Operating Temperature	550°F (287°C)
Warm-up Time	15 min.
Recirculating Air Fan	One fan at 2050 RPM
Air Velocity	3000 fpm (1524 cm/sec) (Average)
Bake Time	3 min. 0 sec. Bake Time minimum 30 min. 0 sec. Bake Time maximum

SERIES BE3240 ELECTRICAL SPECIFICATIONS

Main Blower & Elements Voltage	Control Circuit Voltage	Phase	Frequency	Amperage Draw	Poles	Wires
208-240V	208-240V	3 Ph	50/60 Hz	100 Amp	4 Pole	4 Wire (3 hot, 1 grd)
HEATER AMPERAGE						
		Voltage	kW	Amp	Average Amps	
		208	27	75	37	37
		240	27	65	33	33
380-400V Export	208-240V	3 Ph	50/60 Hz	50 Amp	4 Pole	5 Wire (3 hot, 1neut, 1 grd)
HEATER AMPERAGE						
		Voltage	kW	Amp	Average Amps	
		380-400	27-29.9	40-44	22	22
480V	208-240V	3 Ph	50/60 Hz	50 Amp	4 Pole	5 Wire (3 hot, 1neut, 1 grd) 240V Control Circuit
HEATER AMPERAGE						
		Voltage	kW	Amp	Average Amps	
		480	27	32.5	28	28

STANDARD FINGER CONFIGURATION



- A** = 51020 PLATE, OUTER L67
50550 PLATE, INR/COL L6 ALUZ
42410-0199 ASSY, MANIFOLD W/PERF BAFFEL AL BFL
- B** = 51021 PLATE, OUTER L65
50550 PLATE, INR/COL L6 ALUZ
42410-0199 ASSY, MANIFOLD W/PERF BAFFEL AL BFL
- C** = 50551 PLATE, OUTER L6 GN
50553 PLATE, INR/COL L6 GN ALUZ
50227 ASSY, MANIFOLD L6GN PERF BAFFEL
- D** = 35210-0536 PLATE, BLANK FULL ALUZ

50593 Rev. B

BE3240-SERIES ELECTRIC OVEN KEY PARTS

ITEM	PART NO.	DESCRIPTION	QUANTITY
1	47321	Kit, Temperature Control On/Off Pid	1
2	44687	Blower/Fan Motor	1
3	47797	Conveyor Drive Motor, Standard Speed	1 or 2
3A	47799	Conveyor Drive Motor, High Speed	1 or 2
3B	50265	Sensor, Pickup	1 or 2
3C	45017	Kit, Brushes, Springs & Caps	1 or 2
4	37337	Conveyor Speed Control	1 or 2
5	33812-3	Thermocouple	3
6	44914	Relay, Solid State with Cooling Fan 208V/240V	2
6	44568	Relay, Solid State with Cooling Fan 380V/480V	2
7	27375-0001	Heater Element, 208V, 4500W	6
7	27375-0002	Heater Element, 240V, 4500W	6
7	27375-0003	Heater Element, 380V, 4500W	6
7	27375-0004	Heater Element, 480V, 4500W	6
8	50610	Air Switch	1
9	33983	High Limit Control, 240V	1
10	44549	Contact, 85A	2
11	36451	Cooling Fan, 230V	2
12	28041-0011	Contact, Blower/Motor	1
13	45019	Circuit Breaker, 63A, 3 Pole	2
14	50450	Fan Belt, 2050 RPM, 60 Cycle	1
14A	50584	Fan Belt, 2040 RPM, 50 Cycle	1

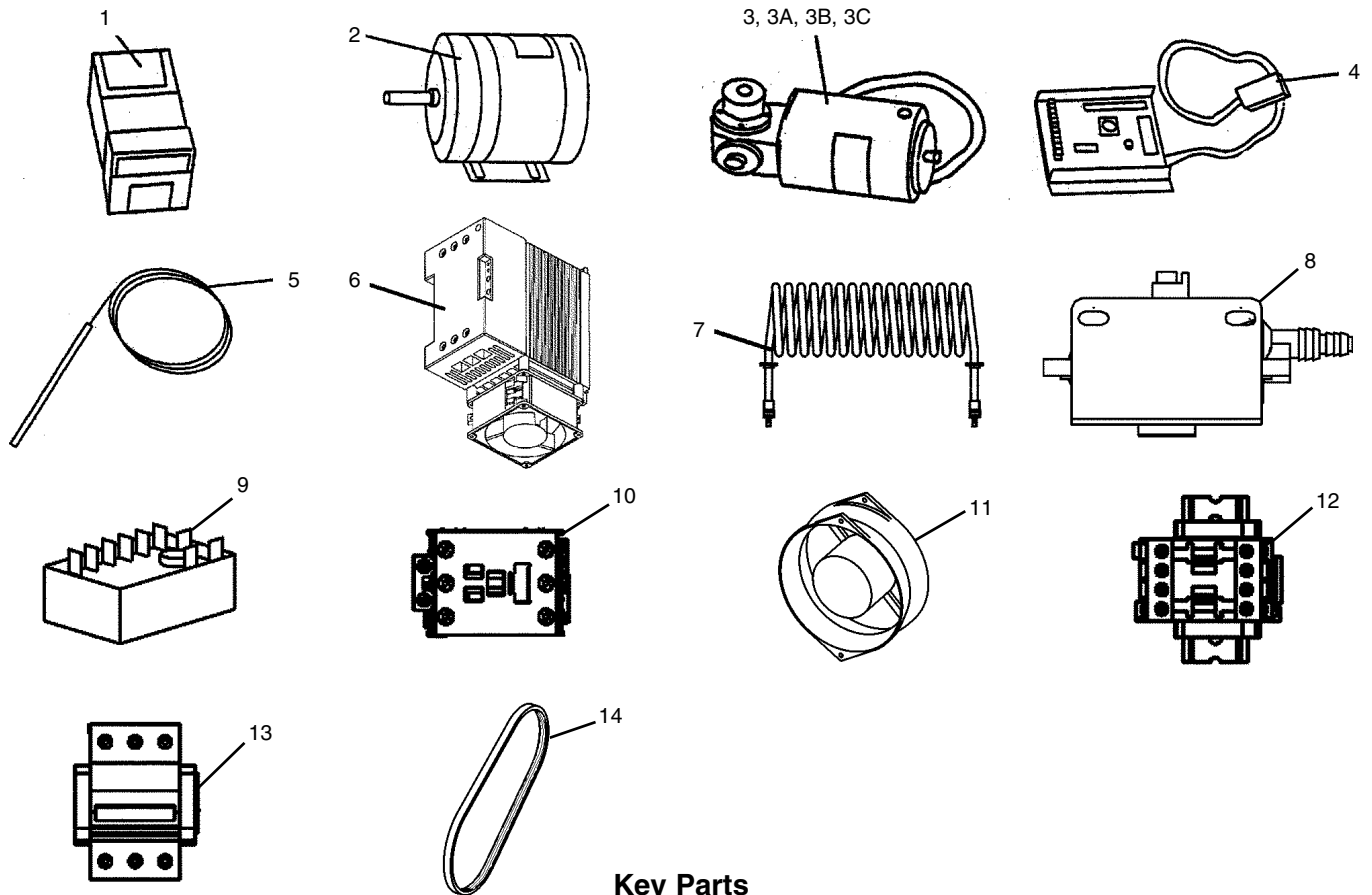

Key Parts

View of Oven Panels, Window and Legs

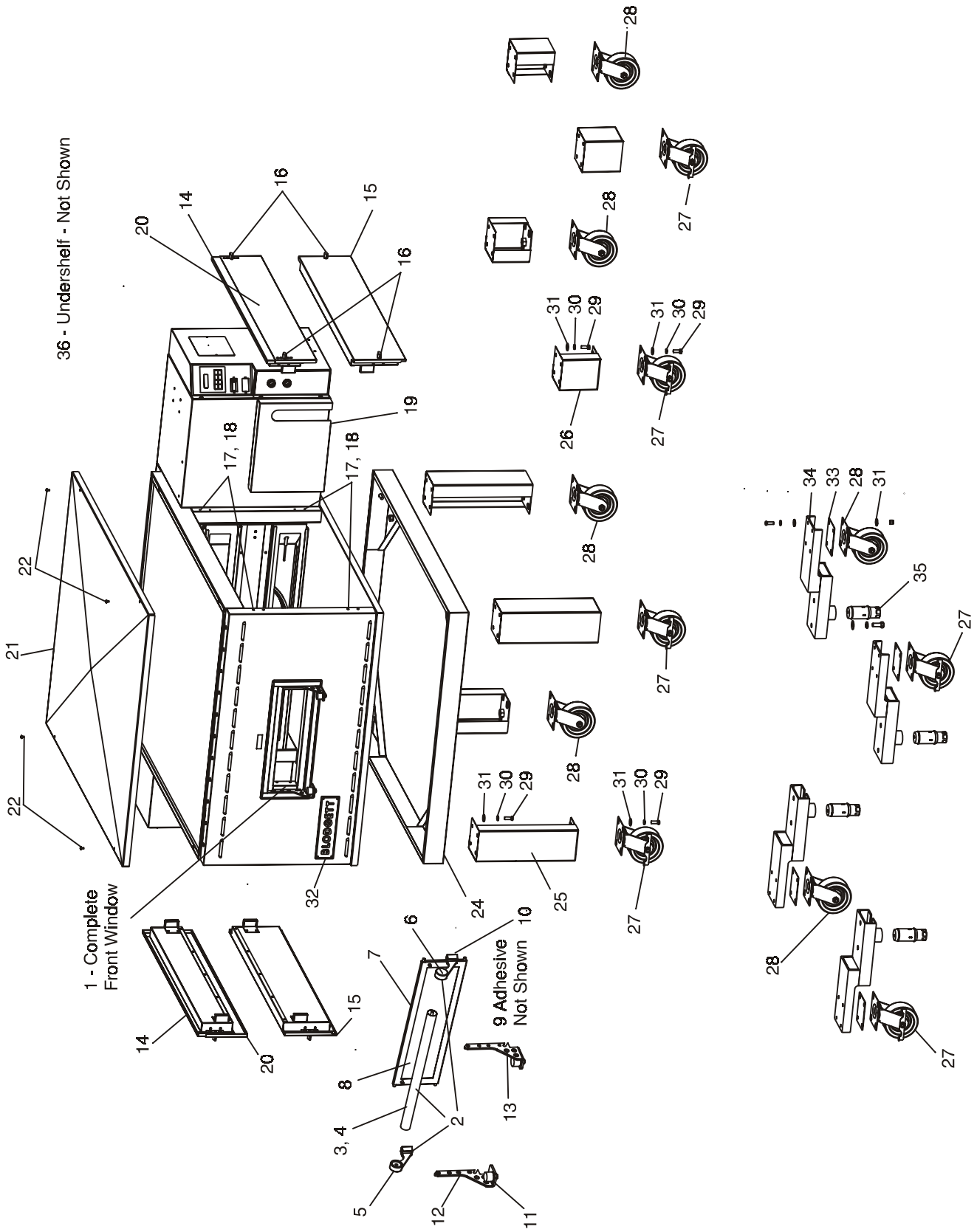

Parts for Oven Panels, Window and Legs

ITEM	QTY.	P/N	DESCRIPTION
1	1	51054	ASSEMBLY, WINDOW, w/HANDLE, ITEMS 1-10
2	1	51081	ASSEMBLY, HANDLE, ITEMS 3-6
3	1	M10092	HANDLE, OUTER
4	1	M10127	HANDLE, INNER THREADED
5	1	M1115	HANDLE, BRACKET (LEFT)
6	1	M1116	HANDLE, BRACKET (RIGHT)
7	1	51087	FRAME AND WINDOW, ITEMS 8-9
8	1	M10198	GLASS, 4.1" X 15.150"
9	1	M1965	ADHESIVE (NOT SHOWN)
10	2	M1118	SCREW-ATTACHES HANDLE
11	2	30927	BUMPER
12	1	51210	BRACKET, WINDOW HINGE (LEFT)
13	1	51211	BRACKET, WINDOW HINGE (RIGHT)
14	2	50178	UPPER END PLUG ASSY
15	2	49945	LOWER END PLUG ASSY
16	8	36452	WINGNUT, PLASTIC 1/4-20
17	8	45449	END PLUG MOUNTING PLATE ASSY

ITEM	QTY.	P/N	DESCRIPTION
18	16	21296-0005	SCR, HEX WSHHD12-14X3/4", SS BSD
19	1	51094	CONVEYORCHAIN COVER
20	2	50637	EYEBROW
21	1	33486	COVER, TOP 304 PANEL
22	4	21256-0008	SCR, 10-32X3/8 18-8 SL TRUSS
24	1	54606	COMPLETE BASE WLDMT
25	4	37900-0024	LEG/TOP PLATE WLDMT-15"
26	4	37900-0102	LEG, 6" H/TOP PLATE WLDMT
27	2	22290-0009	CASTER, SWVL W/BRAKE FLAT PLATE
28	2	22290-0010	CASTER, SWVL FLAT PLATE
29	A/R	220373	SCR, HEX HEAD 3/8-16X1 SST
30	A/R	21422-0001	WASHER, LOCK SPLIT 3/8
31	A/R	21416-0001	FLAT WASHER, 3/8 ZP
32	1	57399	NAME PLATE BLODGETT
33	4	45205	QUAD CASTER SPACER
34	4	45209	QUAD OUTRIGGER WLDMT
35	4	45206	QUAD ADJUSTMENT FOOT INSERT
36	1	58705	UNDERSHELF (NOT SHOWN)

View of Right-hand Control Compartment

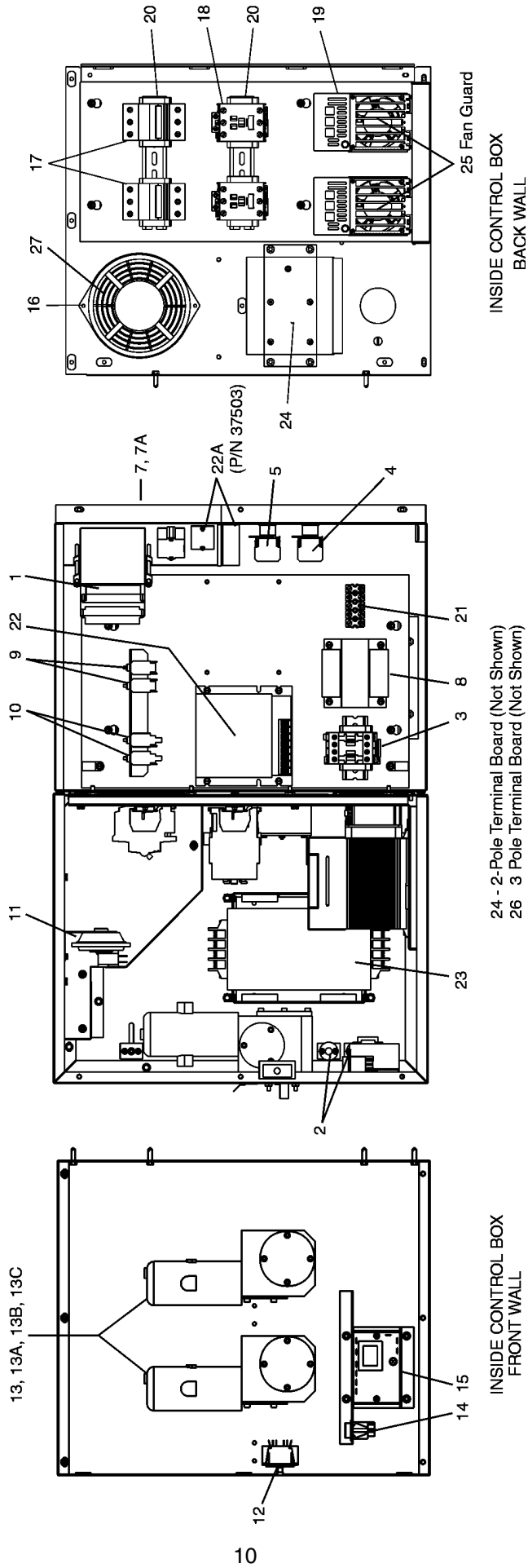

Parts for Right-hand Control Compartment

ITEM	QTY.	P/N	DESCRIPTION
1	1	47321	TEMP CONTROLLER
2	2	33812-3	THERMOCOUPLE, TYPE J SHIELDED 9.50 x 60", TOP-TEMP CONTROL, BOTTOM-HIGHLIMIT
3	1	28041-0011	CONTACTOR, 208/240V
4	1	46521	KIT, CONVEYOR SWITCH CONTAINS ((1) 44697, (1) 44696)
5	1	46522	KIT, BLOWER/HEAT SWITCH CONTAINS ((2) 44697, (1) 44696)
8	1	31504	TRANSFORMER, 230V (P)/120V (S) 200VA
9	2	45036	CIRCUIT BREAKER, 240V 3A
10	2	46831	CIRCUIT BREAKER, 240V 8A
11	1	50610	AIR SWITCH, 0.16" WC
12	1	28021-0047	INTERLOCK SWITCH, 10A NO2P
13	1 OR 2	47797	MOTOR, GEAR 1/50HP 1350:1, STANDARD SPEED
13A	1 OR 2	47799	MOTOR, GEAR 1/30HP 311:1, HIGH SPEED
13B	1 OR 2	50265	SENSOR, PICKUP
13C	1 OR 2	45017	KIT, BRUSHES, SPRINGS, AND CAPS
14	1	35145	SWITCH, PB MOLVENO 250V, RESET, W/GREEN LIGHT
15	1	33983	ELECTRIC HI-LIMIT CONTROL, 240V
16	1	36451	COOLING FAN, 230V AC
17	2	45019	BREAKER, CKT 480VAC 63A 3 POLE
18	2	44549	CONTACTOR, 230VAC COIL 85A
19	2	44914	RELAY, SOLID STATE WITH COOLING FAN, 208-240V
19	2	44568	RELAY, SOLID STATE WITH COOLING FAN, 380-480V
20	10	33363	END, STOP ENTRELEC
21	1	39258	BLOCK, TERMINAL 600V 50A 5 POLE
22	1 OR 2	37337	CONVEYOR SPEED CONTROL W/DIGITAL SPEED DISPLAY
22A	1 OR 2	37503	DIGITAL SPEED CONTROL (DISPLAY ONLY)
23	2	45244	FILTER, RFI 50A/440V/3PH/50/60Hz (CE OVENS ONLY)
24	2	27480-0001	BLOCK, POWER DIST 2 POLES 600V (NOT SHOWN)
25	2	27470-0004	GUARD, FAN - 4.12" DIAMETER
26	1	44390	TERMINAL BLOCK, 600V/50A/3POLE
27	1	31497	GUARD, FINGER - 6.375" DIAMETER

View of Blower Area

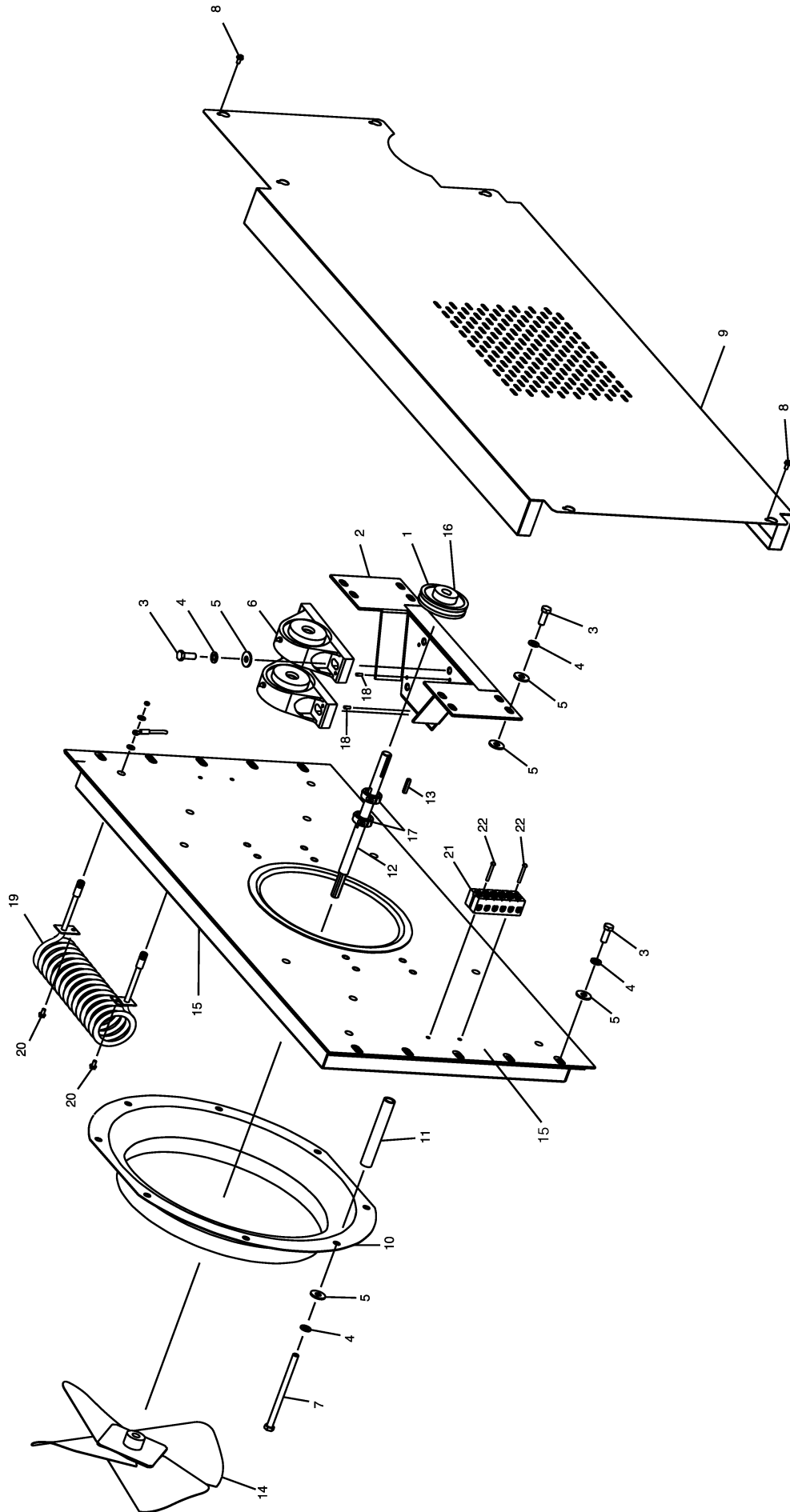

Parts for Blower Area

ITEM	QTY.	P/N	DESCRIPTION
1	1	51157	PULLEY, 1GRV 3.0PD AK32H - 3.25" DIAMETER
2	1	48855	WELDMNT, BRG BRACKET PS540G
3	22	220373	SCREW, HH 3/8" - 16 x 1" SS T
3A	AVR	17110-0017	NEVER SEIZE LUBRICANT - USED ON ITEMS 3 & 7 APPLIED TO THREADS BEFORE REINSTALLING
4	30	A11039	SPLIT LOCK WASHER 3/8" ZP
5	38	21416-0001	FLAT WASHER 3/8" SS
6	2	22072-0025	BEARING, PILLOW BLOCK 5/8"
7	8	21326-0002	SCREW, HX HD GRS 3/8" - 16 x 5-1/2"
8	AVR	2000203	SCREW, HX W/HD 10 - 32 x 3/8" ZC
9	1	48872	BACK WALL SHROUD
10	1	48803	AIR INLET RING
11	8	35900-0108	FAN ORIFICE STAND OFF TUBE
12	1	50643	FAN DRIVE SHAFT
13	1	21651-0010	KEY, SQ 3/16" x 3/16" x 1.00" STL
14	1	48862	AXIAL FAN, 14" DIAMETER
15	1	51115	INR/OTR BACK WELDMNT
16	1	50222	SPECIAL BUSHING, 5/8" ID - 3/16" x 3/32" KEY
17	2	35323	COUPLING, COLLAR SPLIT 5/8" DIAMETER
18	4	50271	ROLL PIN, PLN 5/32" x 7/16"
19	6	27375-0001	HEATER, TBLR COIL-208V/4500W
19	6	27375-0002	HEATER, TBLR COIL-240V/4500W
19	6	27375-0003	HEATER, TBLR COIL-380V/4500W
19	6	27375-0004	HEATER, TBLR COIL-480V/4500W
20	12	2000203	SCR, SL HX W/HD MS 10-32 x 3/8" ZC
21	1	35986	BLOCK, TERM 6-POLE 600V 85A
22	2	15048801	SCR, RHM 8-32 x 1-1/4" NP

View of Blower/Motor Compartment

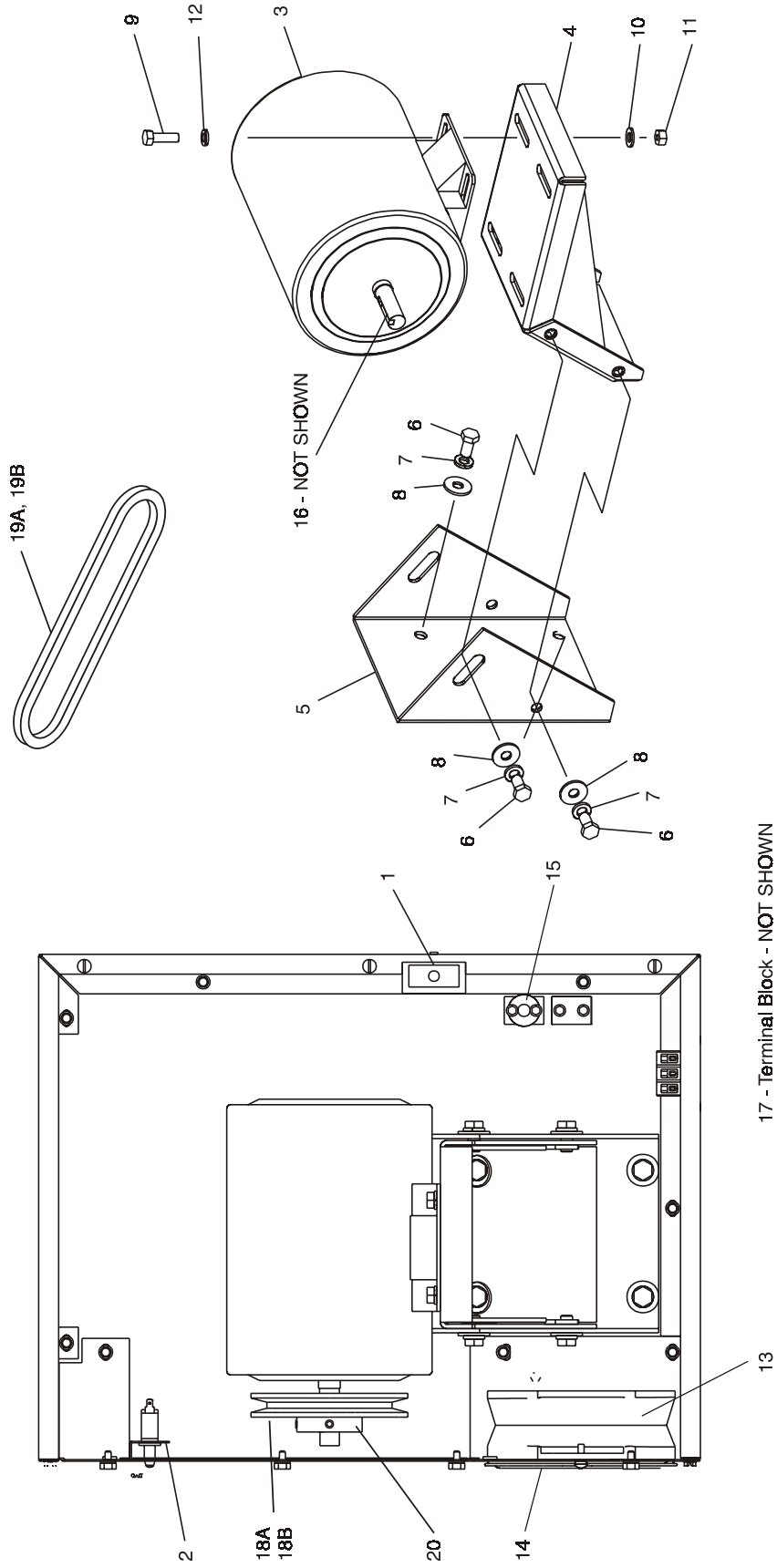

Parts for Blower/Motor Compartment

ITEM	QTY.	P/N	DESCRIPTION
1	1	28021-0047	INTERLOCK SWITCH 10A NO2P
2	1	28021-0061	MOMENTARY SWITCH - 10A NO 2 POLE
3	1	44687	MOTOR 1/2 HP
4	1	49953	MOTOR MOUNTING BRACKET WELDMENT
5	1	50449	MOTOR SUPPORT BRACKET
6	8	1513D8805	SCREW, HEX HD 3/8"-16 x 3/4" - NP
7	8	21422-0001	LOCK WASHER, SPLIT 3/8" ZP
8	8	21416-0001	FLAT WASHER SS 3/8"
9	4	A3896	MACHINE SCREW, HEX HD 5/16"-18 x 1" 18-8
10	4	3023A8807	FLAT WASHER 5/16" SAE NP
11	4	21126-0004	HEX NUT SS 5/16-18
12	4	21421-0004	LOCK WASHER 5/16"
13	1	36451	COOLING FAN 230V AC
14	1	31497	FINGER COOLING FAN GUARD
15	1	33812-3	THERMOCOUPLE, TYPE "J" SHIELDED 9.50 x 60"
16	1	21651-0010	KEY - MOTOR, 3/16 X 3/16 X 1
17	1	44390	TERMINAL BLOCK - 600V, 50A, 3 POLE
18A	1	51158	PULLEY - 3.75" DIAMETER, 60Hz (AK39H)
18B	1	51160	PULLEY - 4.45" DIAMETER, 50Hz (AK46H)
19A	1	50450	BELT - 63.2" OUTSIDE LENGTH, 60Hz
19B	1	50584	BELT - 64.2" OUTSIDE LENGTH, 50Hz
20	1	50222	SPECIAL BUSHING

RPM KIT P/N	HERTZ	MOTOR PULLEY W/SPLIT BUSHING	MTR PULLEY P/N SPLIT BUSH P/N	BELT SIZE DESCRIPTION	BELT P/N	RPM OF FAN
51079	50	AK46H PULLEY H 5/8 SPLIT BUSHING	51160 50222	AX62	50584	2040
51077	60	AK39H PULLEY H 5/8 SPLIT BUSHING	51158 50222	AX61	50450	2050

View of "Single" Belt Conveyor

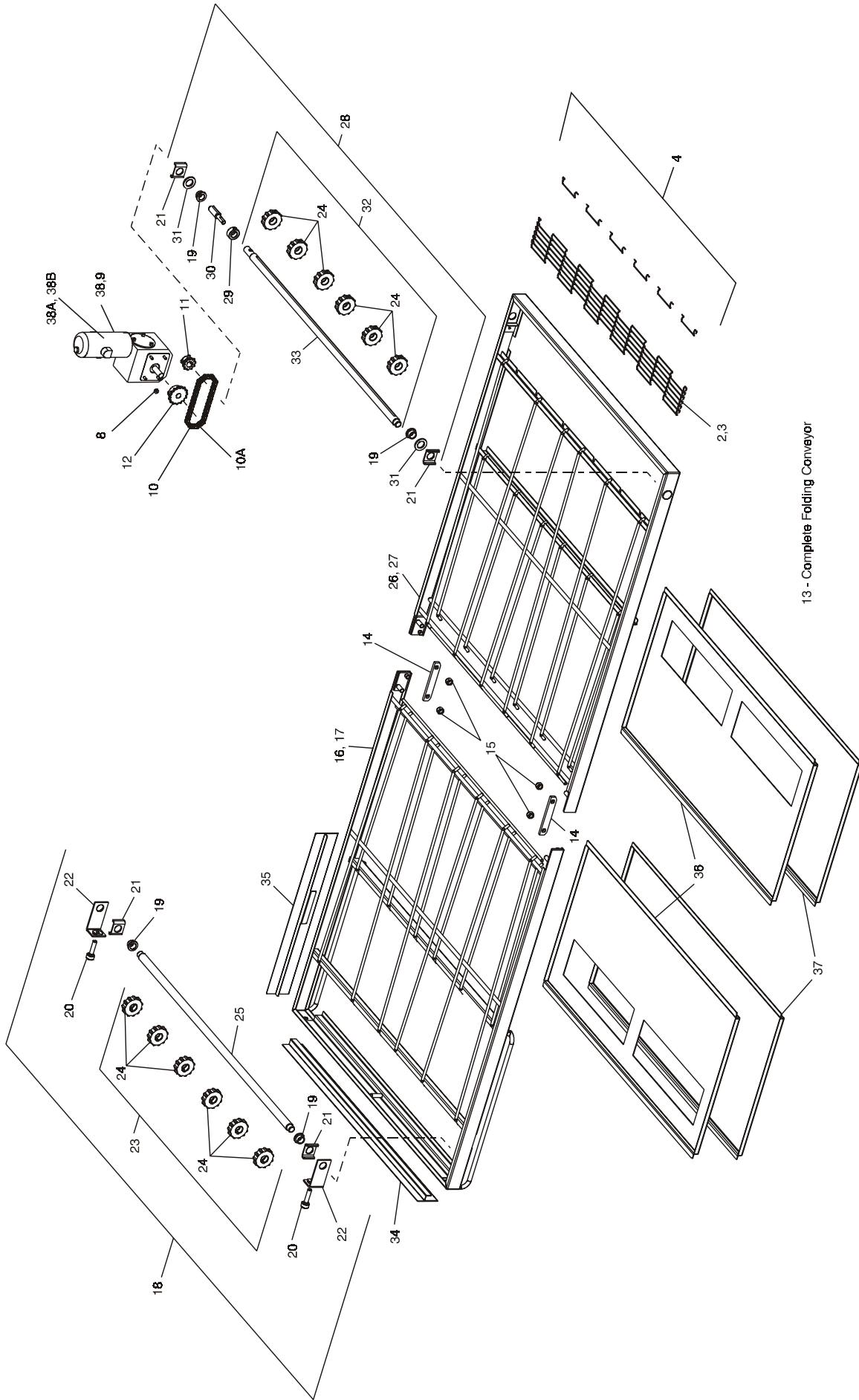

13 - Complete Folding Conveyor

Parts for "Single" Belt Conveyor

ITEM	QTY.	P/N	DESCRIPTION	ITEM	QTY.	P/N	DESCRIPTION
2	1	22450-0225	CONVEYOR BELT, 1/2P 32" x 204" 2.84/11 S	22	2	37000-0413	IDLER SHAFT SUPPORT BRACKET
3	AVR	33900-0032	CONVEYOR CHAIN, SS WIRE 1 FT	23	1	49400-0014	IDLER SHAFT ASSEMBLY INCLUDES ITEMS 24 & 25
4	1	51380	KIT, MASTER LINK, CONTAINS ((1) 33900-0016, (4) 33900-0017, (1) 33900-0018)	24	12	22229-0003	CONVEYOR DRIVE SPROCKET 2.0" OD W/SCREW
8	4	2001371	NUT, KEPS 10-32, ZP	25	1	35000-1011	IDLER SHAFT - CONVEYOR
9	1	50265	CONVEYOR CONTROL PICKUP KIT (NOT SHOWN)	26	1	54961	CONVEYOR FRAME ASSEMBLY - DRIVE INCLUDES ITEMS 27 & 28
10	1	49400-0050	ROLLER CHAIN ASSEMBLY, W/MASTER LINK	27	1	54960	COMPLETE CONVEYOR FRAME WELDMENT - DRIVE
10A	1	22273-0002	MASTER LINK	28	1	54948	DRIVE SIDE ASSEMBLY - CONVEYOR INCLUDES ITEMS 19, 21, 29, 30, 31 & 32
11	1	22151-0002	SPROCKET, #35-10T-5/8"-SHAFT	29	1	22011-0013	SHAFT COLLAR W/SCREW
12	1	22151-0003	SPROCKET, #35-15T-1/2"-MOTOR	30	1	35000-1013	DRIVE SHAFT ADAPTER
13	1	54976	COMPLETE FOLDING CONVEYOR ASSY INCLUDES ITEMS 14, 15, 16 & 26	31	2	35000-1080	NYLON SPACER 3/4" ID 1-1/4" OD
14	2	35900-0398	PIVOT PLATE - CONVEYOR FRAME	32	1	49400-0012	DRIVE SHAFT ASSEMBLY INCLUDES ITEMS 24 & 33
15	4	21176-0002	LOCKNUT, HEX SS 3/8"-16	33	1	35000-1012	DRIVE SHAFT - CONVEYOR
16	1	54975	CONVEYOR FRAME ASSEMBLY - IDLER INCLUDES ITEMS 17 & 18	34	1	35000-1103	STOP, SIDE END CONVEYOR EXT
17	1	54974	COMPLETE CONVEYOR FRAME WELDMENT - IDLER	35	1	35900-0148	STOP, BACK SIDE CONVEYOR EXT
18	1	54970	IDLER SIDE ASSEMBLY - CONVEYOR INCLUDES ITEMS 19, 20, 21, 22 & 23	36	2	35900-0255	CRUMB PAN W/SLOTS - CONVEYOR - STANDARD
19	4	22034-0003	BUSHING, FLANGE 3/4" OD, x 5/8" ID N/D	37	2	35900-0305	CRUMB PAN - CONVEYOR - SOLID
20	2	35000-1008	SCREW, ADJ - CONVEYOR IDLER	38	1 OR 2	47797	MOTOR, GEAR 1/50HP 1350:1, STANDARD SPEED
21	4	54947	CONVEYOR SHAFT SUPPORT BRACKET	38A	1 OR 2	47799	MOTOR, GEAR 1/30HP 311:1, HIGH SPEED
				38B	1 OR 2	45017	BRUSHES, SPRINGS, AND CAPS

View of "Split" Belt Conveyor

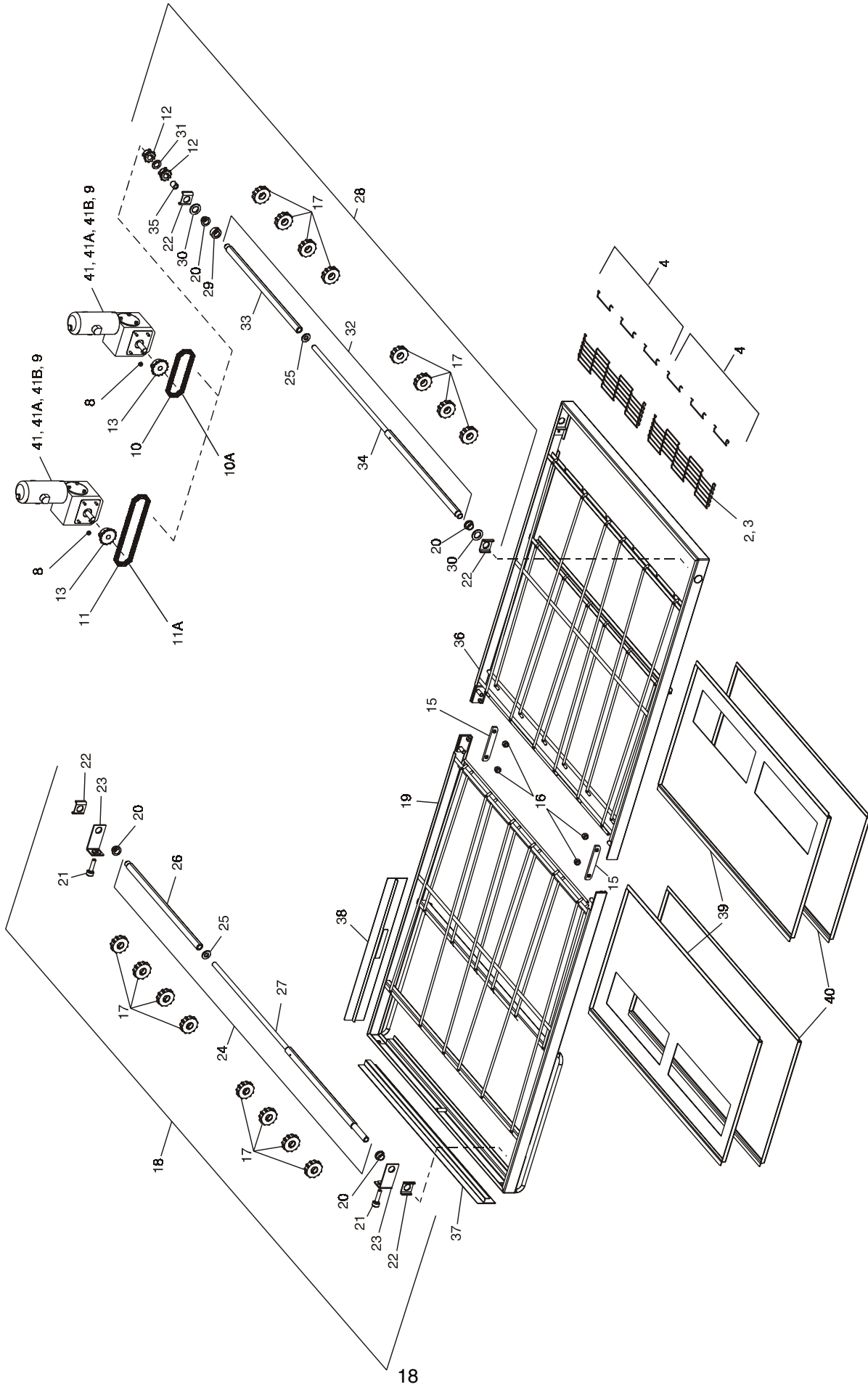

Parts for "Split" Belt Conveyor

ITEM	QTY.	P/N	DESCRIPTION
2	2	22450-0226	CONVEYOR BELT, 1/2P 15" x 146" 2.86/5 SP
3	A/R	33900-0037	CONVEYOR CHAIN, SS WIRE 1 FT
4	2	51382	KIT, MASTER LINK, CONTAINS ((1) 33900-0016, (1) 33900-0017, (1) 33900-0018)
8	8	2001371	NUT, KEPS 10-32, ZP
9	2	50265	CONVEYOR CONTROL PICKUP KIT (NOT SHOWN)
10	1	49400-0070	ROLLER CHAIN ASSEMBLY, SPB 15"
10A	1	22273-0003	MASTER LINK
11	1	49400-0051	ROLLER CHAIN ASSEMBLY, SPB 26-1/2"
11A	1	22273-0003	MASTER LINK
12	2	22159-0003	SPROCKET, #25-20T-5/8" - SHAFT
13	2	22159-0004	SPROCKET, #25-30T-1/2" - MOTOR
15	2	35900-0398	PIVOT PLATE - CONVEYOR FRAME
16	4	21176-0002	LOCKNUT, HEX SS 3/8"-16
17	16	22229-0003	CONVEYOR DRIVE SPROCKET 2.0" OD W/SCREW
18	1	54987	CONVEYOR FRAME ASSEMBLY - IDLER INCLUDES ITEMS 17, 19, 20, 21, 22, 23 & 24
19	1	54974	COMPLETE CONVEYOR FRAME WELDMENT - IDLER
20	4	22034-0003	BUSHING, FLANGE 3/4" OD, x 5/8" ID N/D
21	2	35000-1008	SCREW, ADJ - CONVEYOR IDLER
22	4	54947	CONVEYOR SHAFT SUPPORT BRACKET

ITEM	QTY.	P/N	DESCRIPTION
23	2	37000-0413	IDLER WELDMENT
24	1	35525	IDLER SHAFT ASSEMBLY, SPB INCLUDES ITEMS 25, 26 & 27
25	2	21415-0001	FLAT WASHER, BRONZE
26	1	35000-1535	REAR CONVEYOR IDLER SHAFT, SPB
27	1	42400-0354	FRONT CONVEYOR IDLER SHAFT ASSEMBLY, SPB
28	1	54989	CONVEYOR FRAME-DRIVE ASSY, SPB INCLUDES ITEMS 12, 13, 17, 20, 22, 29, 30, 31, 32, 35 & 36
29	1	22011-0014	SPLIT-SHAFT COLLAR
30	2	35000-1080	NYLON SPACER 3/4" ID 1-1/4" OD
31	1	35000-1531	NYLON SPACER
32	1	35524	DRIVE SHAFT ASSEMBLY, SPB INCLUDES ITEMS 33 & 34
33	1	35900-0022	CONN-REAR CONVEYOR DRIVE SHAFT
34	1	49400-0018	FRONT CONVEYOR DRIVESHAFT ASSY, SPB
35	1	35900-0023	BUSHING, SPROCKET-FRONT DRIVE
36	1	54960	COMPLETE CONVEYOR FRAME- DRIVE WELDMENT
37	1	35000-1103	STOP, SIDE END CONVEYOR EXT
38	1	35900-0148	STOP, BACK SIDE CONVEYOR EXT
39	2	35900-0255	CRUMB PAN W/SLOTS - CONVEYOR
40	2	35900-0305	CRUMB PAN - CONVEYOR
41	2	47797	MOTOR, GEAR 1/50HP 1350:1 (STD SPEED)
41A	2	47799	MOTOR, GEAR 1/30HP 311:1 (HIGH SPEED)
41B	2	45017	BRUSHES, SPRINGS, AND CAPS

BE3240 OVEN INSTALLATION REQUIRED KITS AND EQUIPMENT

TYPE OF INSTALLATION	BE3240 Single Oven Option Base w/15" Legs, Casters & Top Kit P/N 49025-0002	BE3240 Double Oven Option Base w/6" Legs, Casters & Top Kit P/N 49025-0007	BE3240 Triple Oven Option Base w/Casters & Top Kit P/N 51139
BE3240 Single Electric Oven	1		
BE3240 Double Electric Oven		1	
BE3240 Triple Electric Oven			1

PARTS LIST FOR SERIES BE3240 OVEN INSTALLATION KIT P/N 49810-0008 (Two required for double oven) (Three required for triple oven)

ITEM NO.	QTY	PART NO.	DESCRIPTION
2	1	35000-1103	CONVEYOR END STOP
3	1	35900-0148	CONVEYOR LEFT REAR STOP
4	1	58115	SERIES BE3240 OWNER/OPERATOR MANUAL

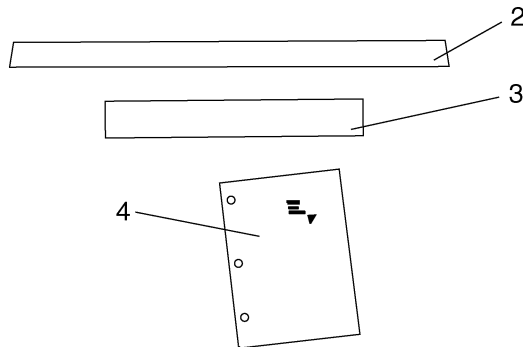

BE3240-Series Electric Oven Installation Parts

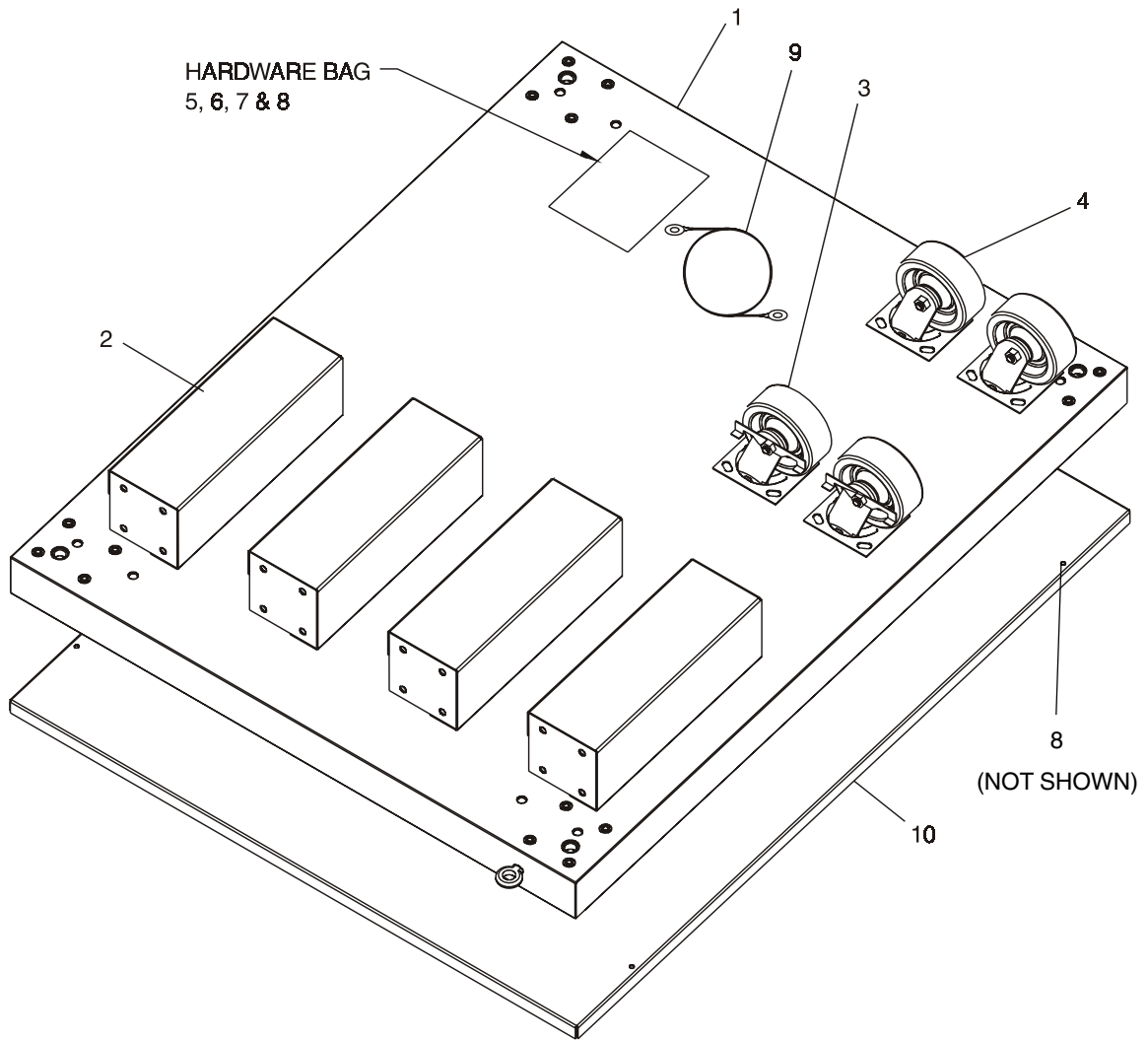

**Model BE3240 Single Oven
Option Base Kit**

**PARTS LIST FOR BE3240 SERIES SINGLE OVEN OPTION - BASE w/15" LEGS & TOP
P/N 49025-0002**

ITEM NO.	QTY	PART NO.	DESCRIPTION
1	1	54606	COMPLETE BASE WELDMENT
2	4	37900-0024	TOP PLATE, LEG WELDMENT - 15"
3	2	22290-0009	SWIVEL CASTER W/BRAKE FLAT PLATE
4	2	22290-0010	SWIVEL CASTER FLAT PLATE
5	32	220373	3/8"-16 x 1" HEX SCREW, SST
6	32	21416-0001	3/8" FLAT WASHER, SS
7	32	21422-0001	3/8" SPLIT LOCK WASHER, ZP
8	4	21256-0008	SCREWS FOR TOP 10-32 x 3/8" 18-8, SL TRUS S
9	1	22450-0228	RESTRAINT CABLE ASSEMBLY
10	1	33486	TOP COVER

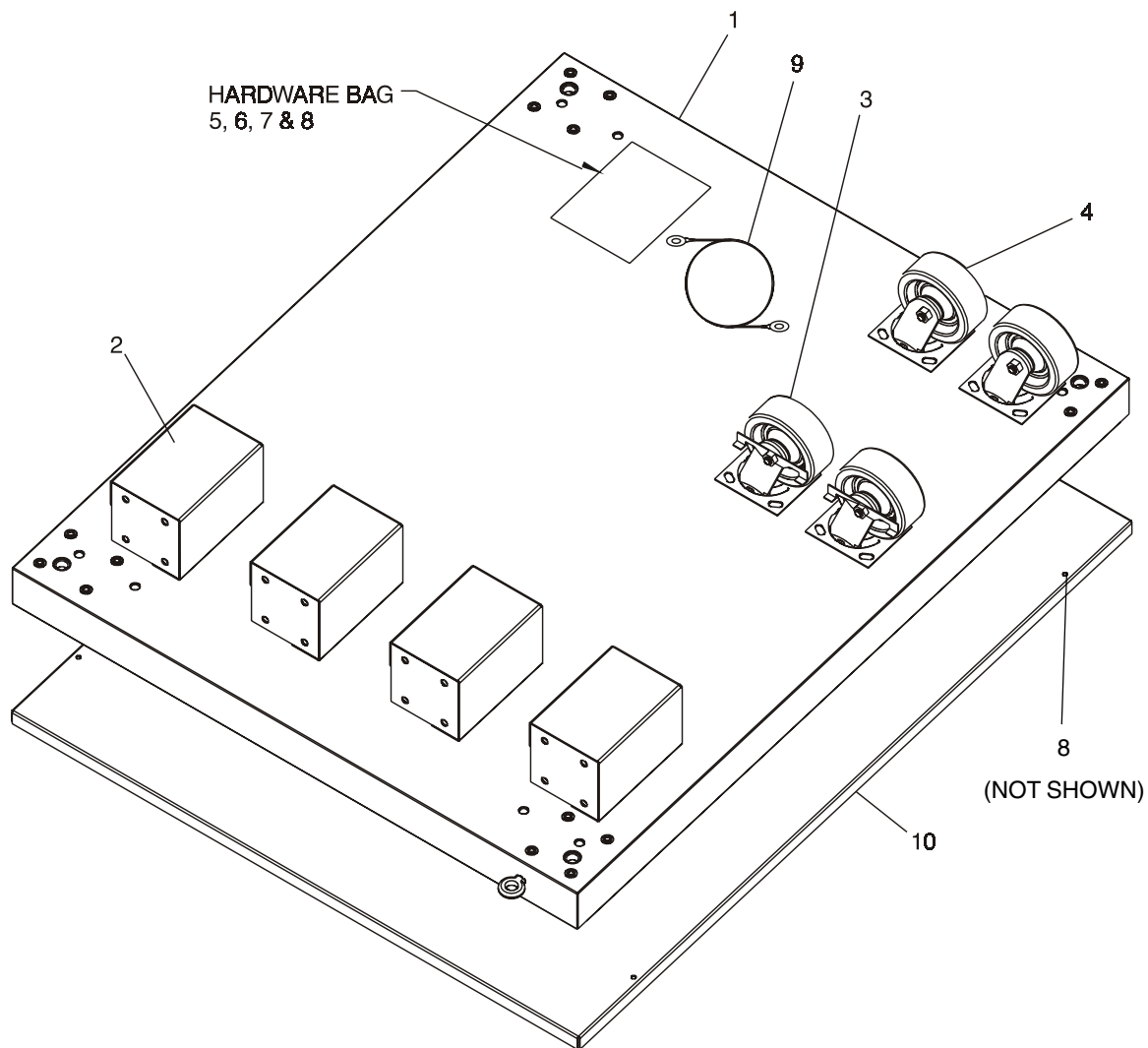

**Model BE3240 Double Oven
Option Base Kit**

**PARTS LIST FOR BE3240 SERIES DOUBLE OVEN OPTION - BASE w/6" LEGS, CASTERS & TOP
P/N 49025-0007**

ITEM NO.	QTY	PART NO.	DESCRIPTION
1	1	54606	COMPLETE BASE WELDMENT
2	4	37900-0102	TOP PLATE, LEG WELDMENT
3	2	22290-0009	SWIVEL CASTER W/BRAKE FLAT PLATE
4	2	22290-0010	SWIVEL CASTER FLAT PLATE
5	32	220373	3/8"-16 x 1" HEX SCREW, SST
6	32	21416-0001	3/8" FLAT WASHER, SS
7	32	21422-0001	3/8" SPLIT LOCK WASHER, ZP
8	4	21256-0008	SCREWS FOR TOP 10-32 x 3/8" 18-8, SL TRUS S
9	1	22450-0228	RESTRAINT CABLE ASSEMBLY
10	1	33486	TOP COVER

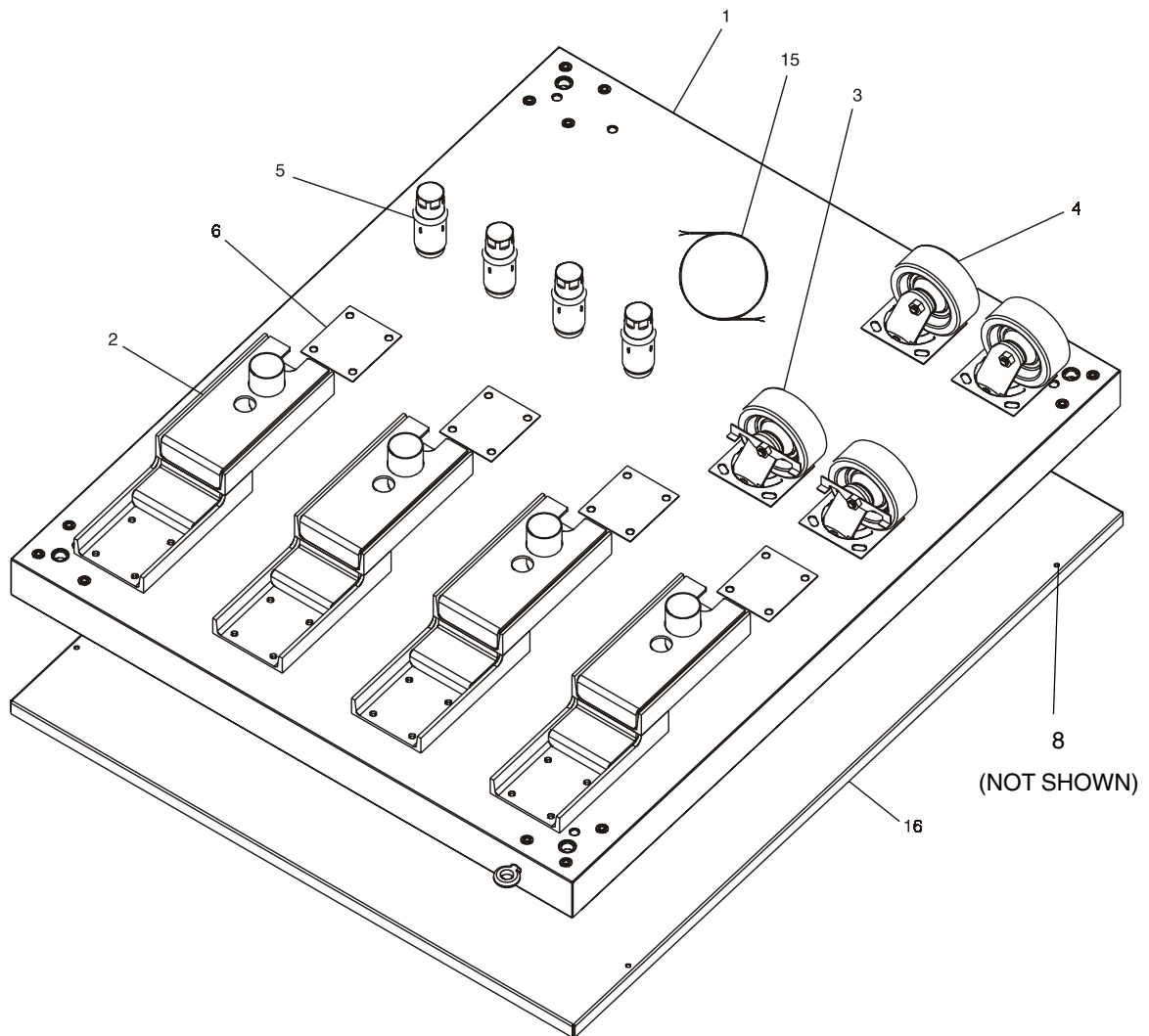

**Model BE3240 Triple Oven
Option Base Kit (Outriggers)**

**PARTS LIST FOR BE3240 SERIES TRIPLE OVEN OPTION - BASE w/CASTERS & TOP
P/N51139**

ITEM NO.	QTY	PART NO.	DESCRIPTION
1	1	54606	COMPLETE BASE WELDMENT
2	4	45209	QUAD OUTRIGGER WELDMENT
3	2	22290-0009	SWIVEL CASTER, W/BRAKE FLAT PLATE
4	2	22290-0010	SWIVEL CASTER, FLAT PLATE
5	4	45206	INSERT,QUAD ADJUSTMENT FOOT
8	4	45205	SPACER,QUAD CASTER
14	4	21256-0008	SCREWS FOR TOP 10-32 x 3/8" 18-8, SL TRUS S
15	1	22450-0228	RESTRAINT CABLE ASSEMBLY
16	1	33486	TOP COVER

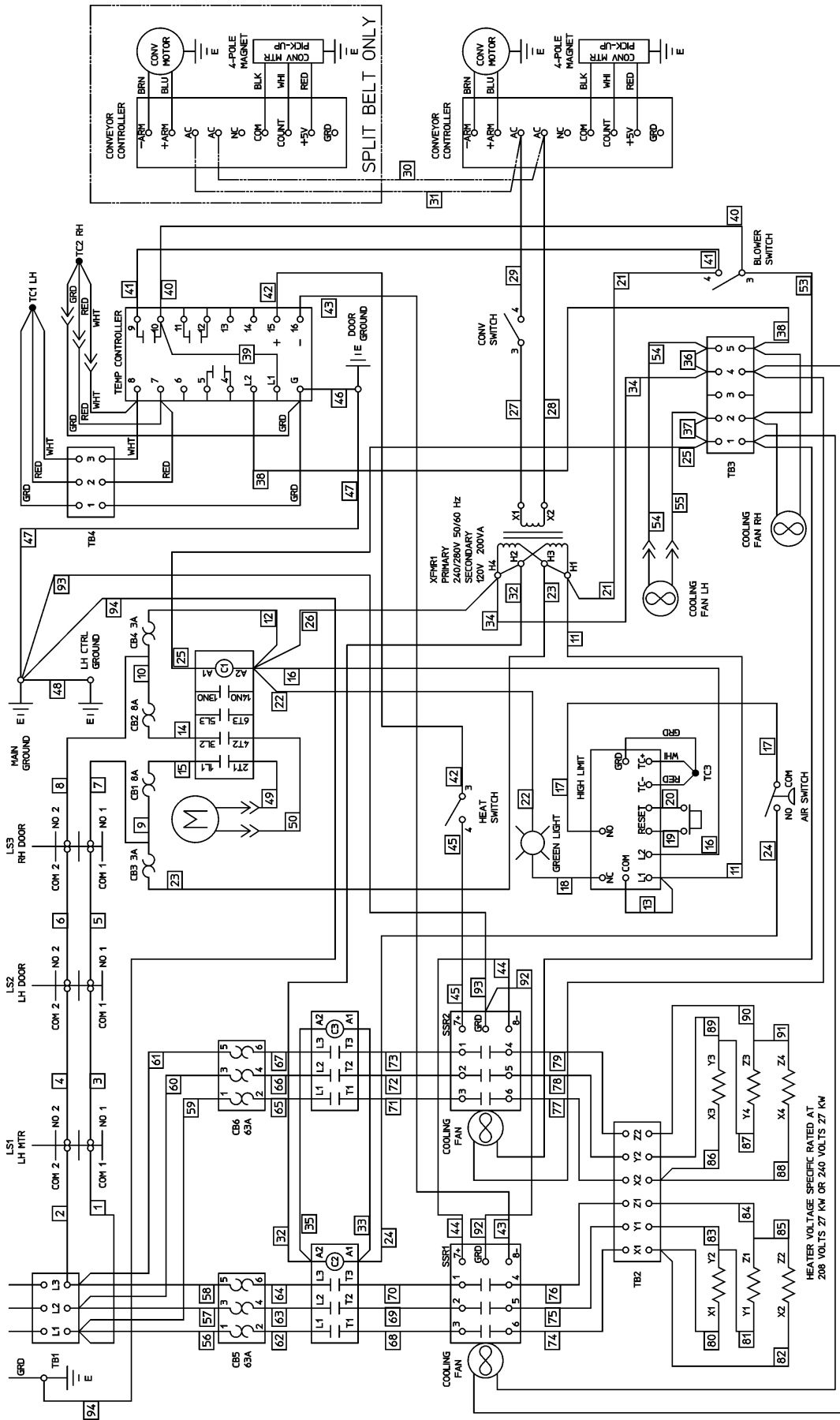

VOLTAGE	TOTAL WATTAGE (KW)	PHASE	AMPERES			
			X	Y	Z	N
208	27.0	3	78.9	74.9	78.9	-
240	27.0	3	68.4	64.9	68.4	-

Blodgett BE3240 Wiring Diagram, E208-240V 50/60 3PH 4W US

50466 Rev. B2

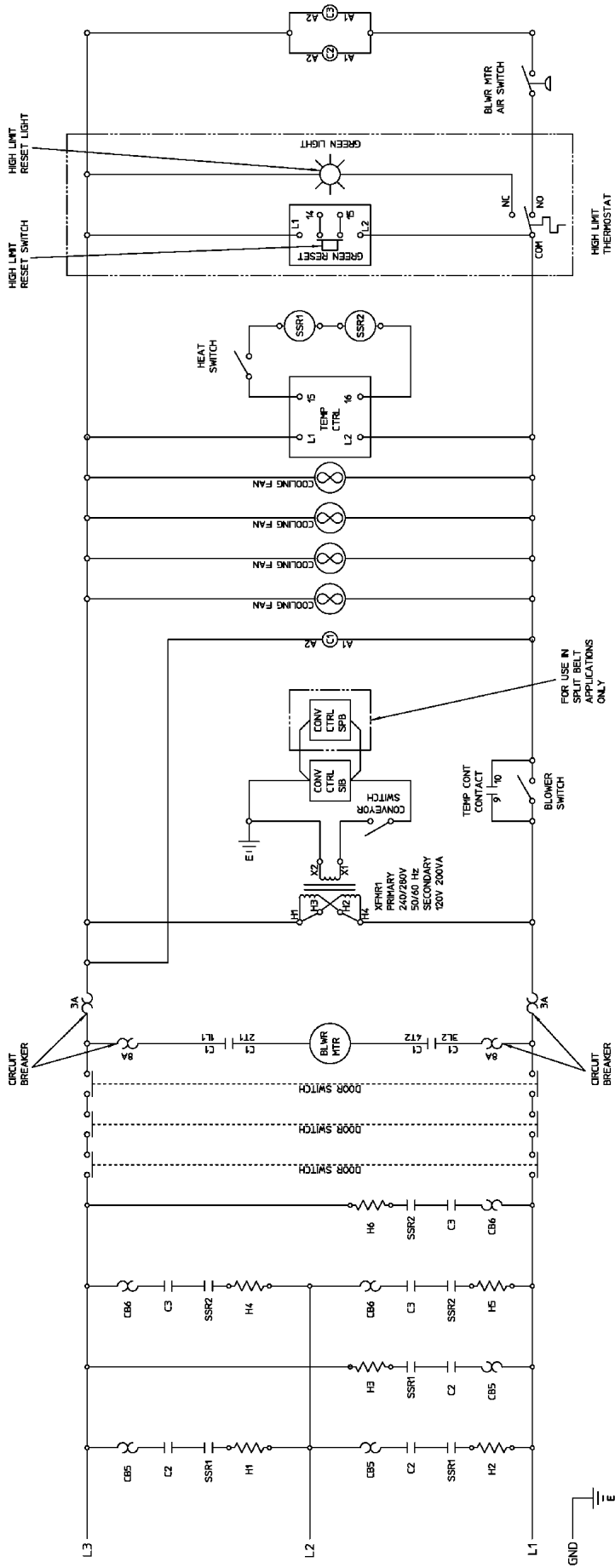

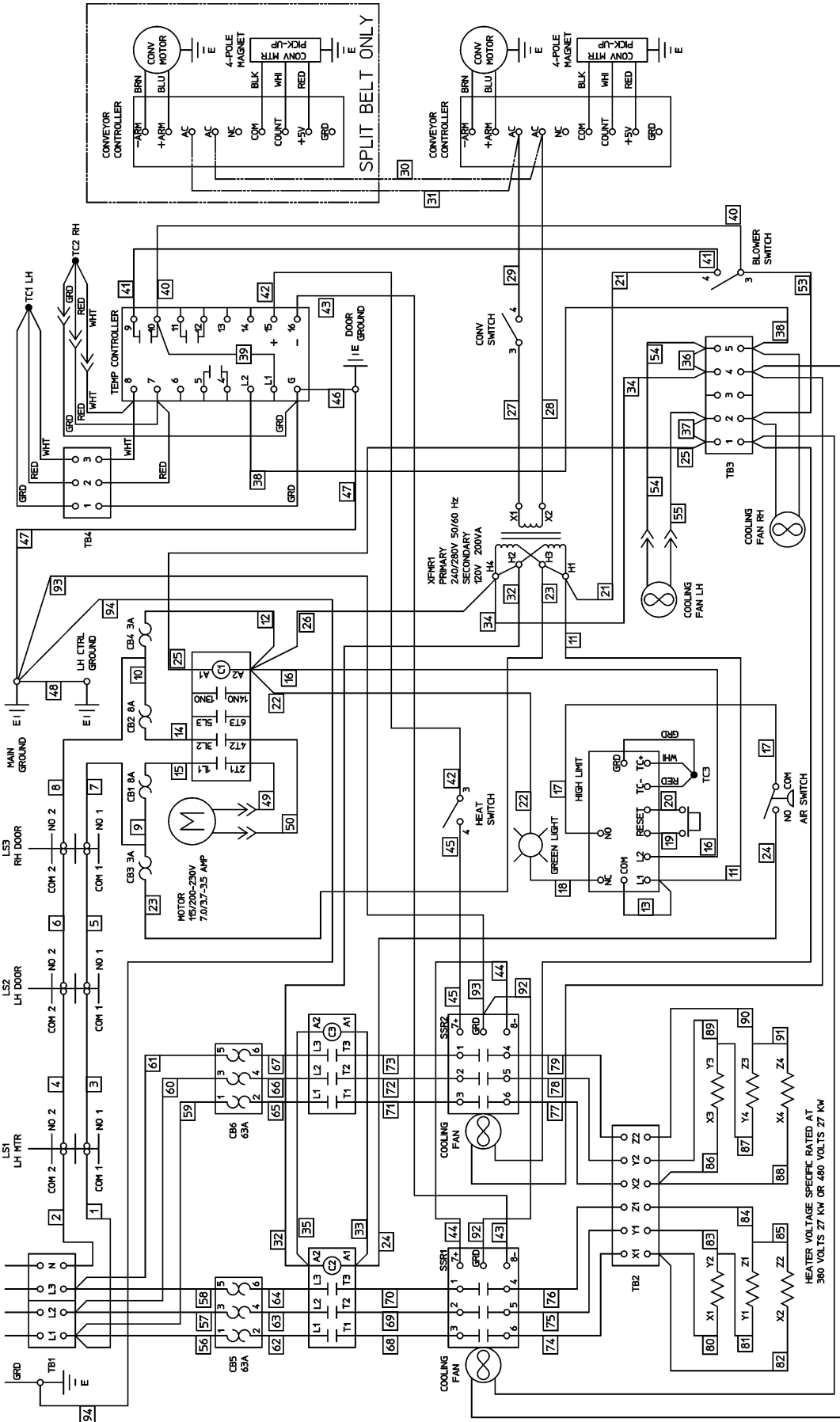

VOLTAGE	TOTAL MATTAGE (KW)	PHASE	AMPERES		
			X	Y	Z
380	27.0	3	44.5	41.0	41.0
480	27.0	3	36.0	32.5	32.5

50140 Rev. B2

Blodgett BE3240 Wiring Diagram, E380-480V 50/60 3PH 5W US

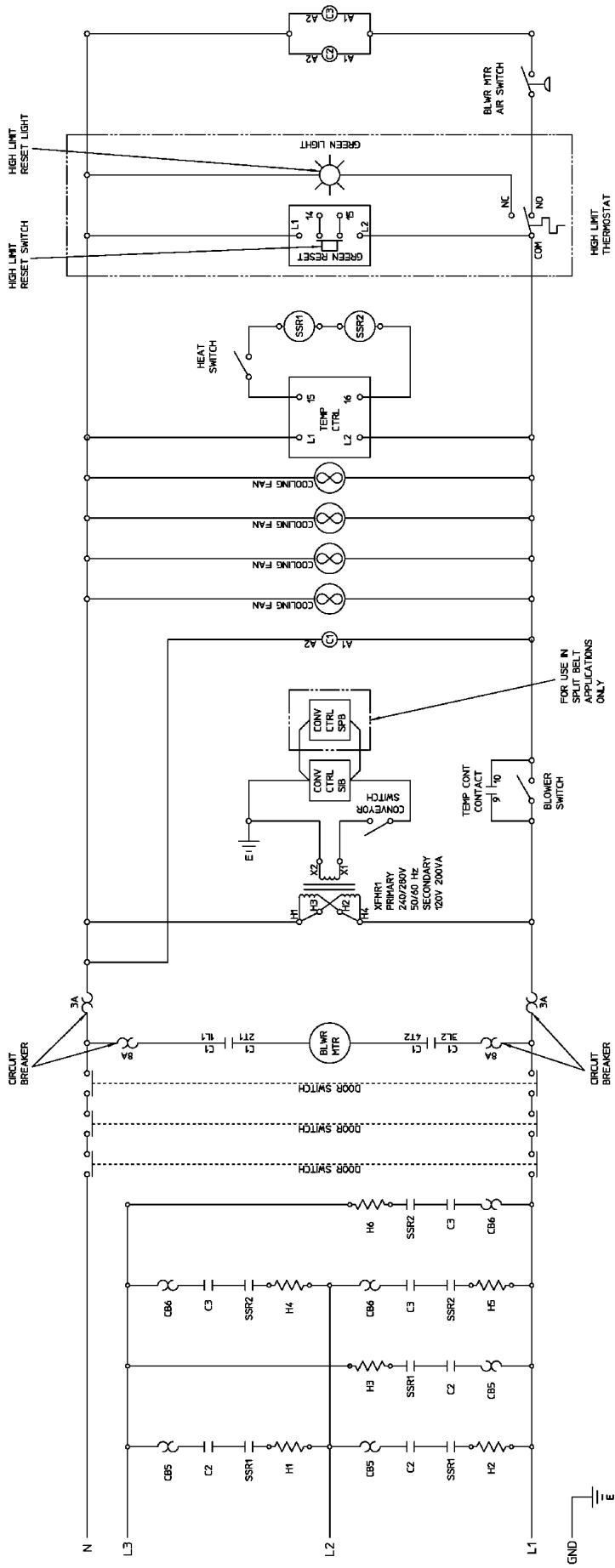

50140 Rev. B1

Blodgett BE3240 Ladder Wiring Diagram, E380-480V 50/60 3PH 5W US

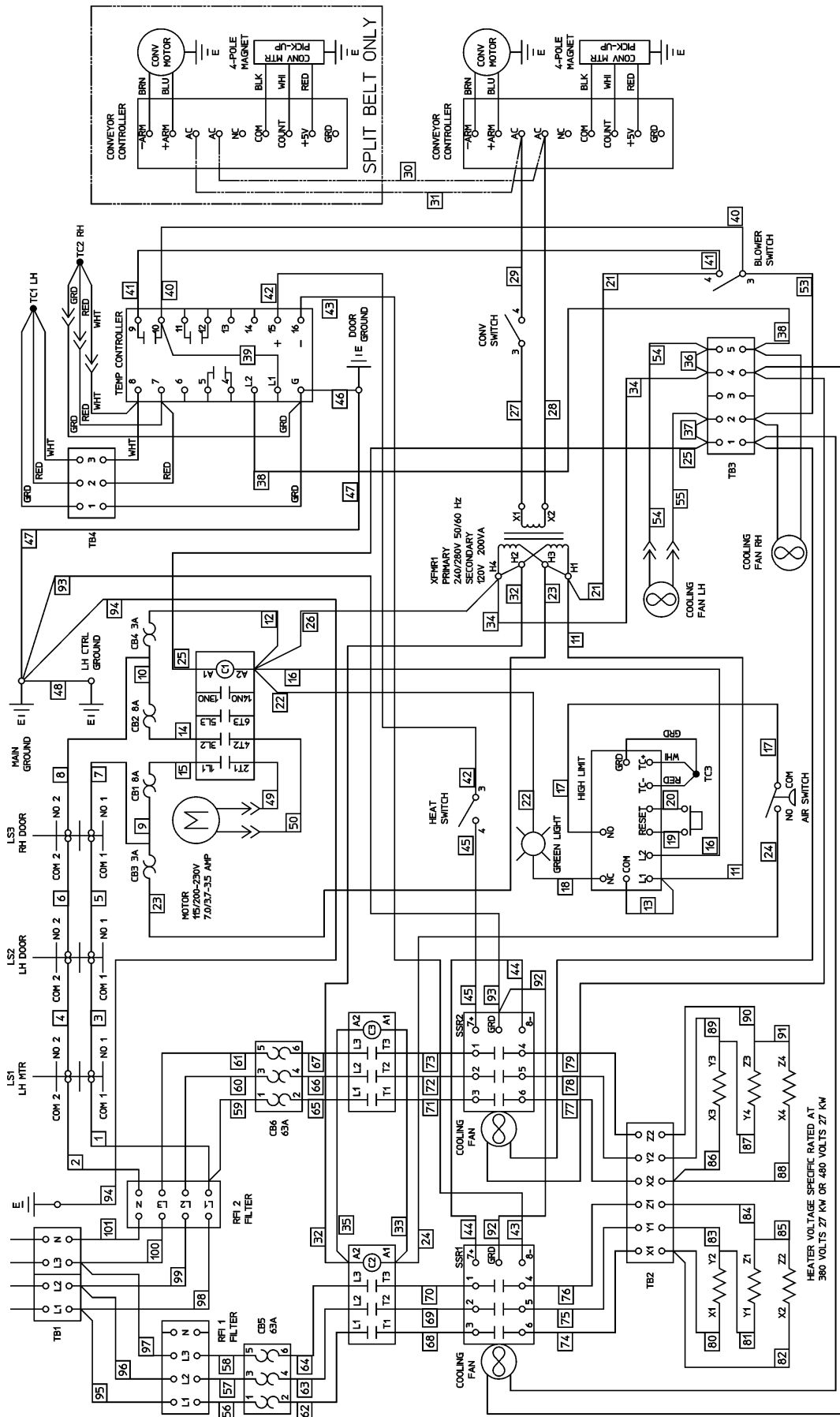

VOLTAGE	TOTAL WATTAGE (KW)	PHASE	AMPERES			
			X	Y	Z	N
380	27.0	3	44.5	41.0	41.0	3.5

Blodgett BE3240 Wiring Diagram, E380V 50/60/3CE 540 ENGLISH

50467 Rev. B2

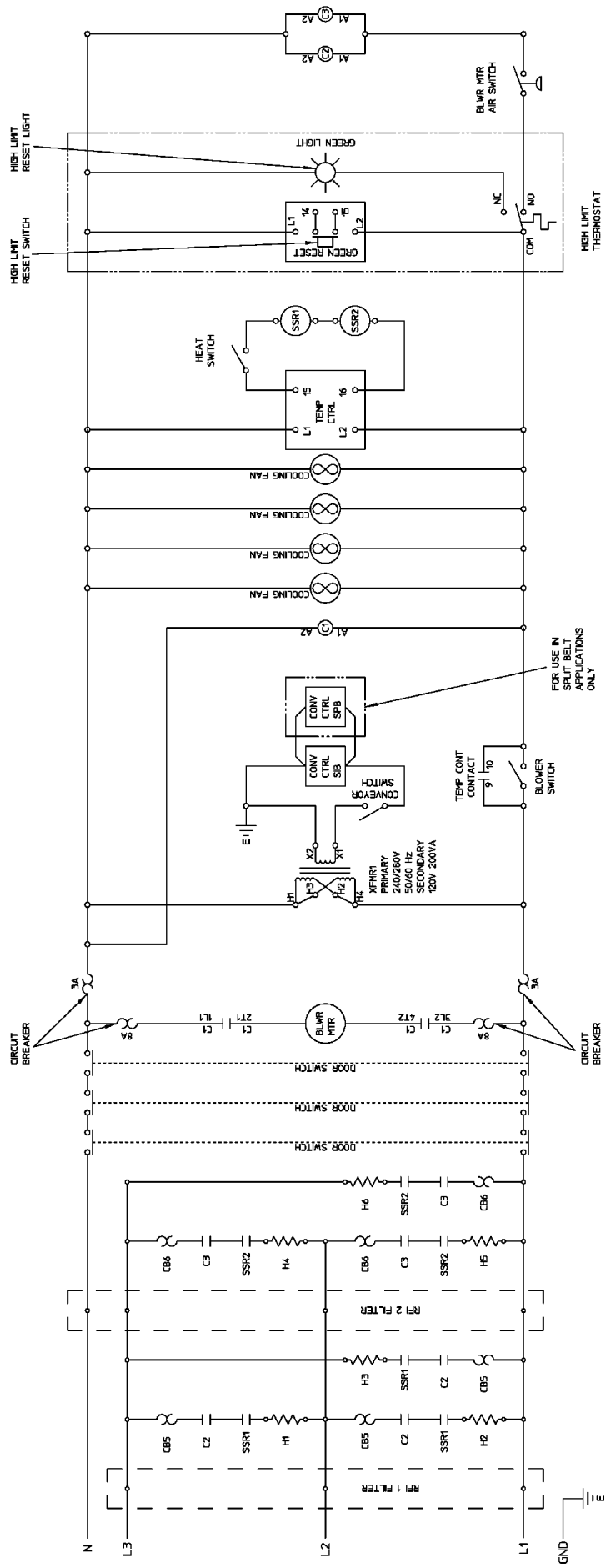

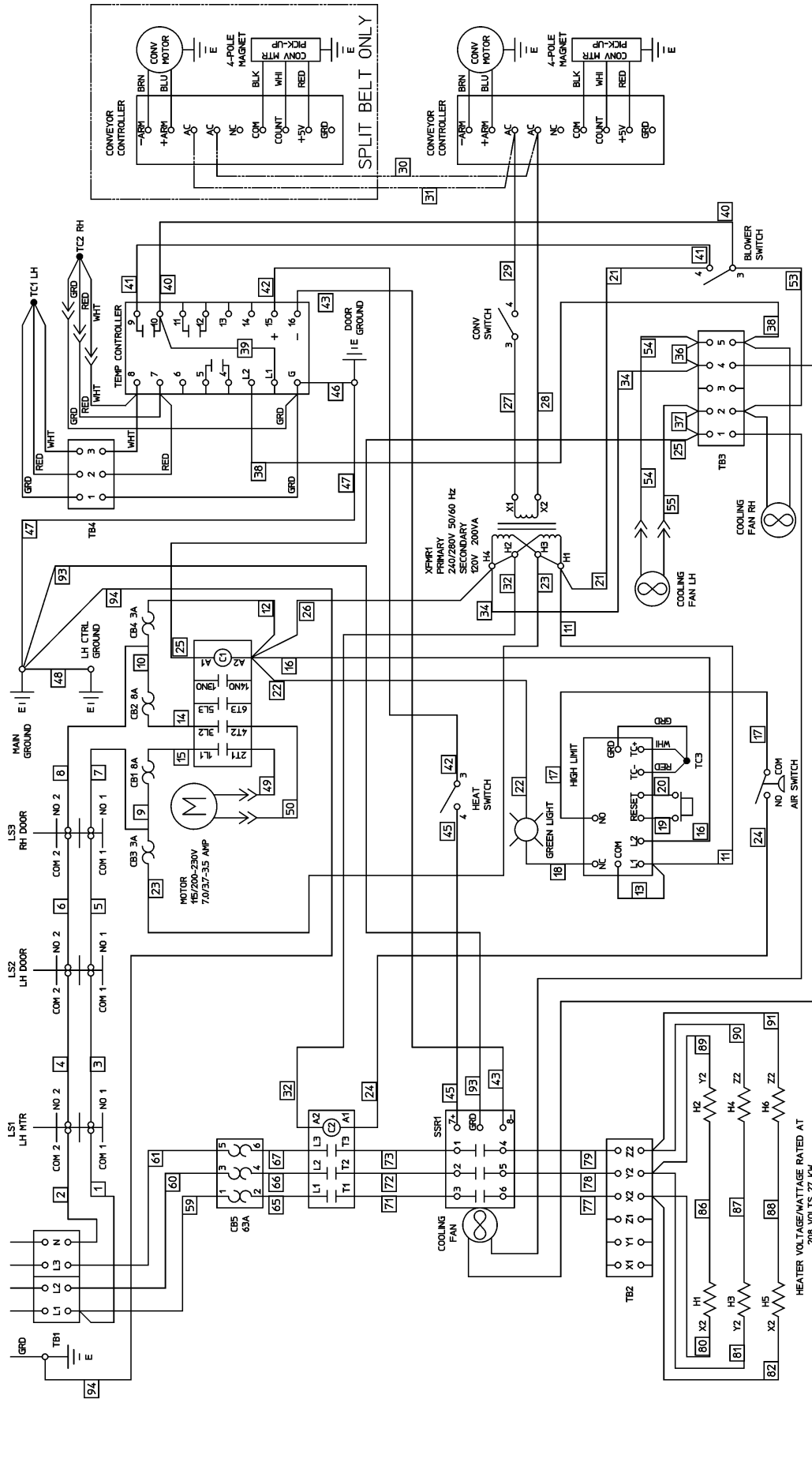

VOLTAGE	TOTAL WATTAGE (KW)	PHASE	AMPERES		
			X	Y	Z
400	27.9	3	43.8	40.3	35
480	27.9	3	42.2	38.7	35

Blodgett BE3240 Wiring Diagram, E400-416 50/60 3PH 5W

51068 Rev. C2

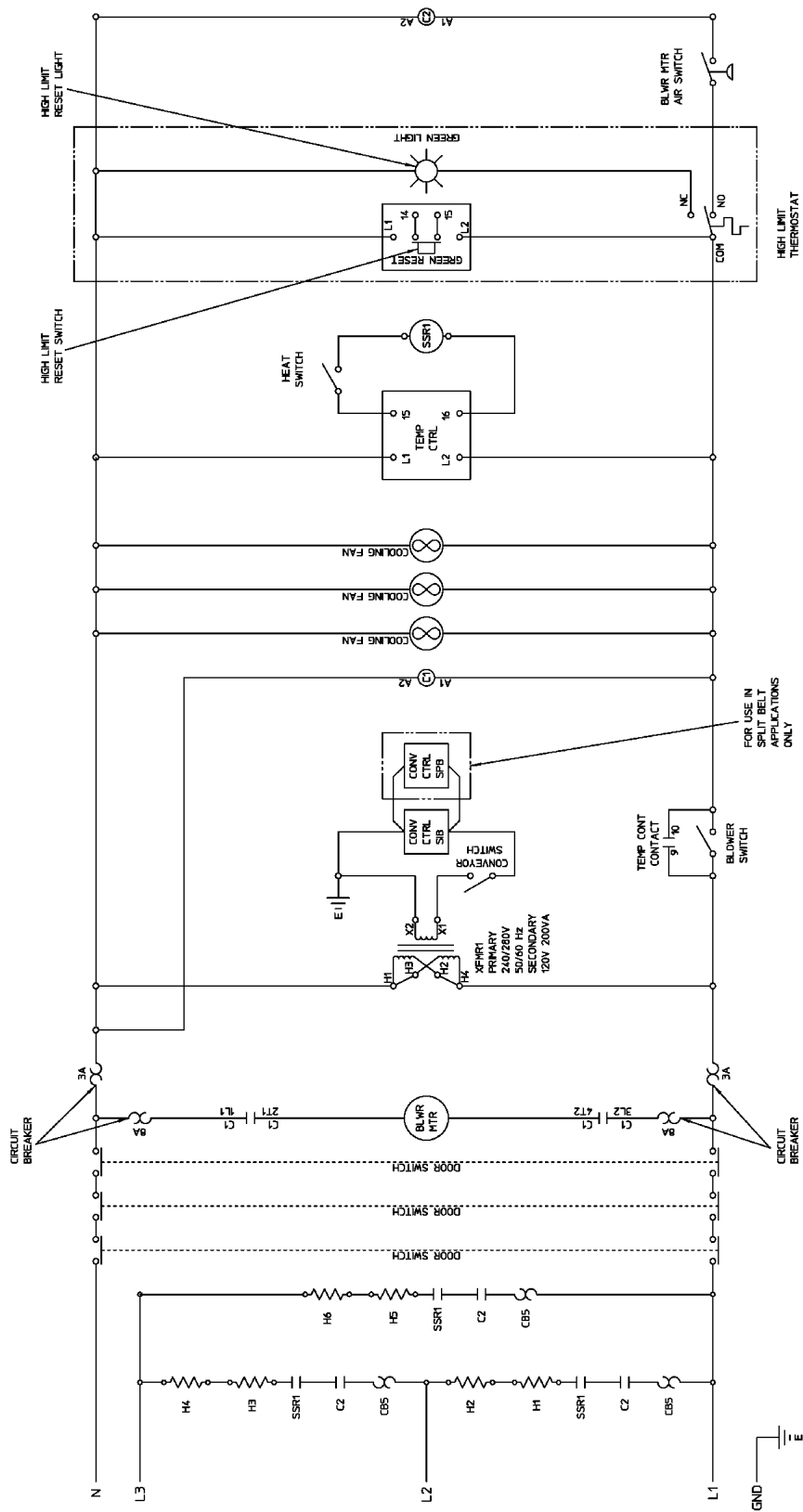

51068 Rev. C1

Blodgett BE3240 Ladder Wiring Diagram, E400-416 50/60 3PH 5W

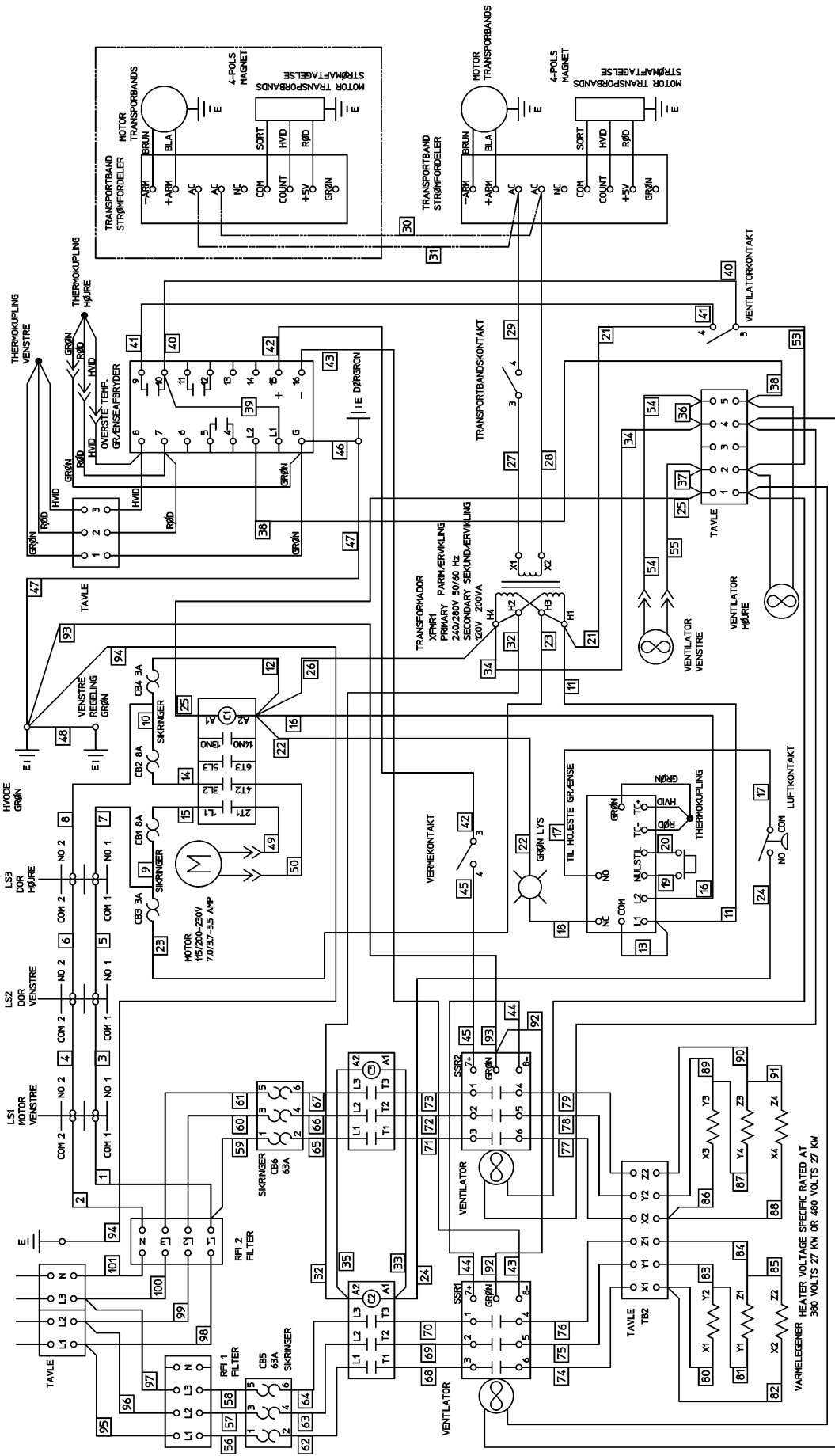

VOLTAGE	TOTAL WATTAGE (KW)	FASE			
		X	Y	Z	N
380	27.0	44.5	41.0	41.0	3.5

Blodgett BE3240 Wiring Diagram, E380/50/60/3 5W CE 540 DN

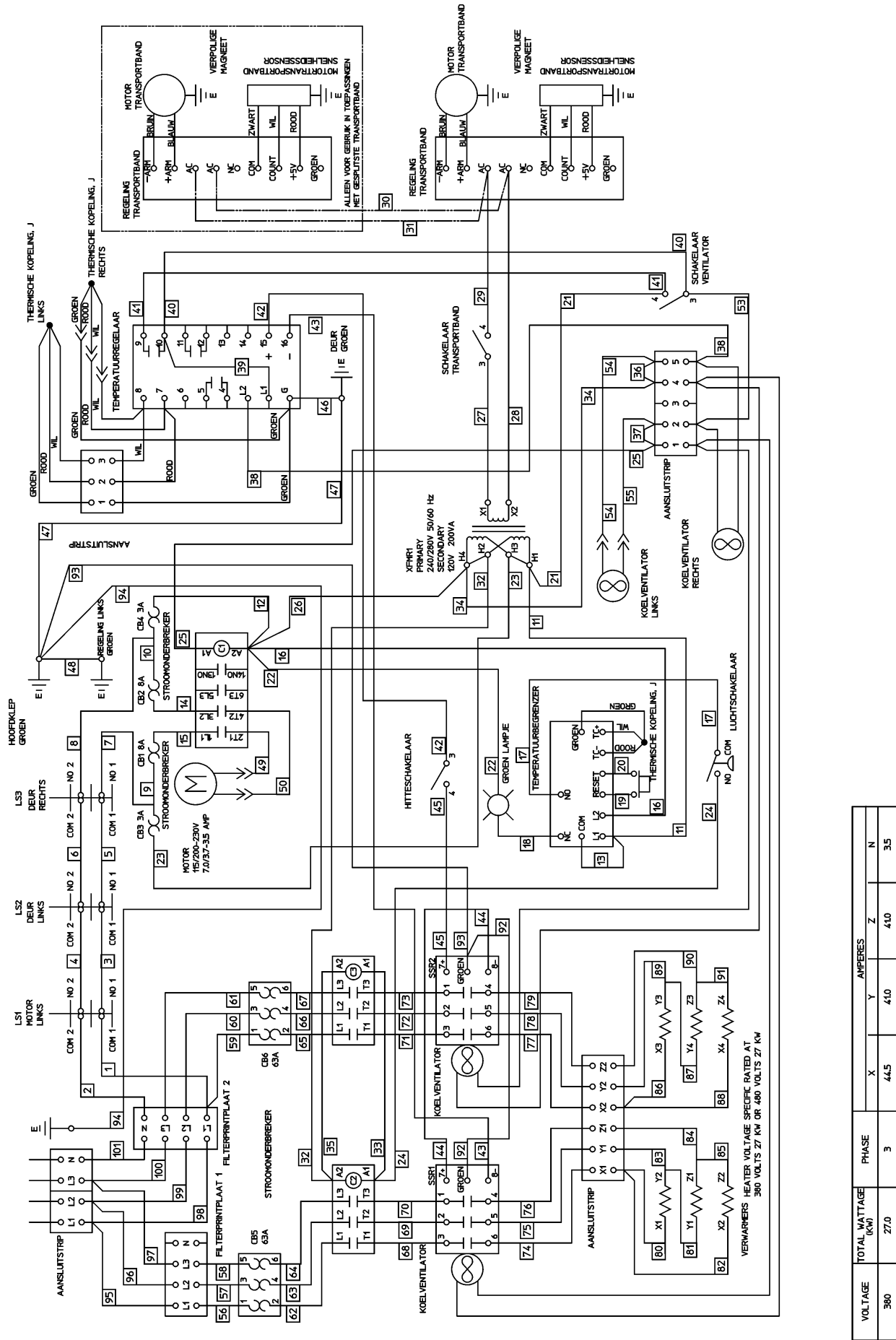

VOLTAGE	TOTAL WATTAGE (KW)	PHASE	AMPERES		
			X	Y	Z
380	27.0	3	44.5	41.0	41.0
					N 3.5

Blodgett BE3240 Wiring Diagram, E380/50/60/3 5W CE 540 DUT

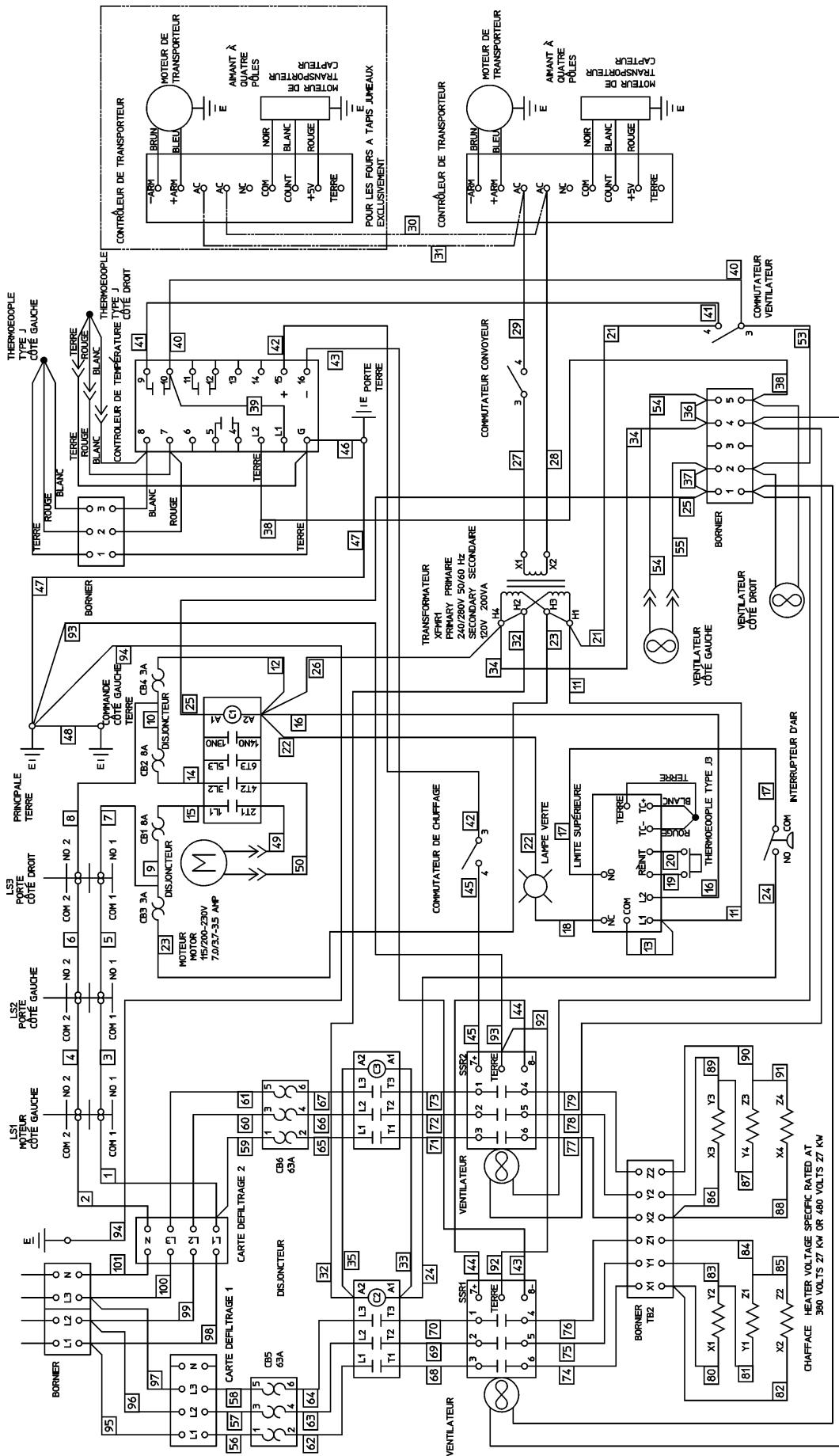

VOLTAGE	TOTAL WATTAGE (KW)	PHASE	X	Y	Z	N
380	27.0	3	44.5	41.0	41.0	3.5

Blodgett BE3240 Wiring Diagram, E380/50/60/3 5W CE 540 FR

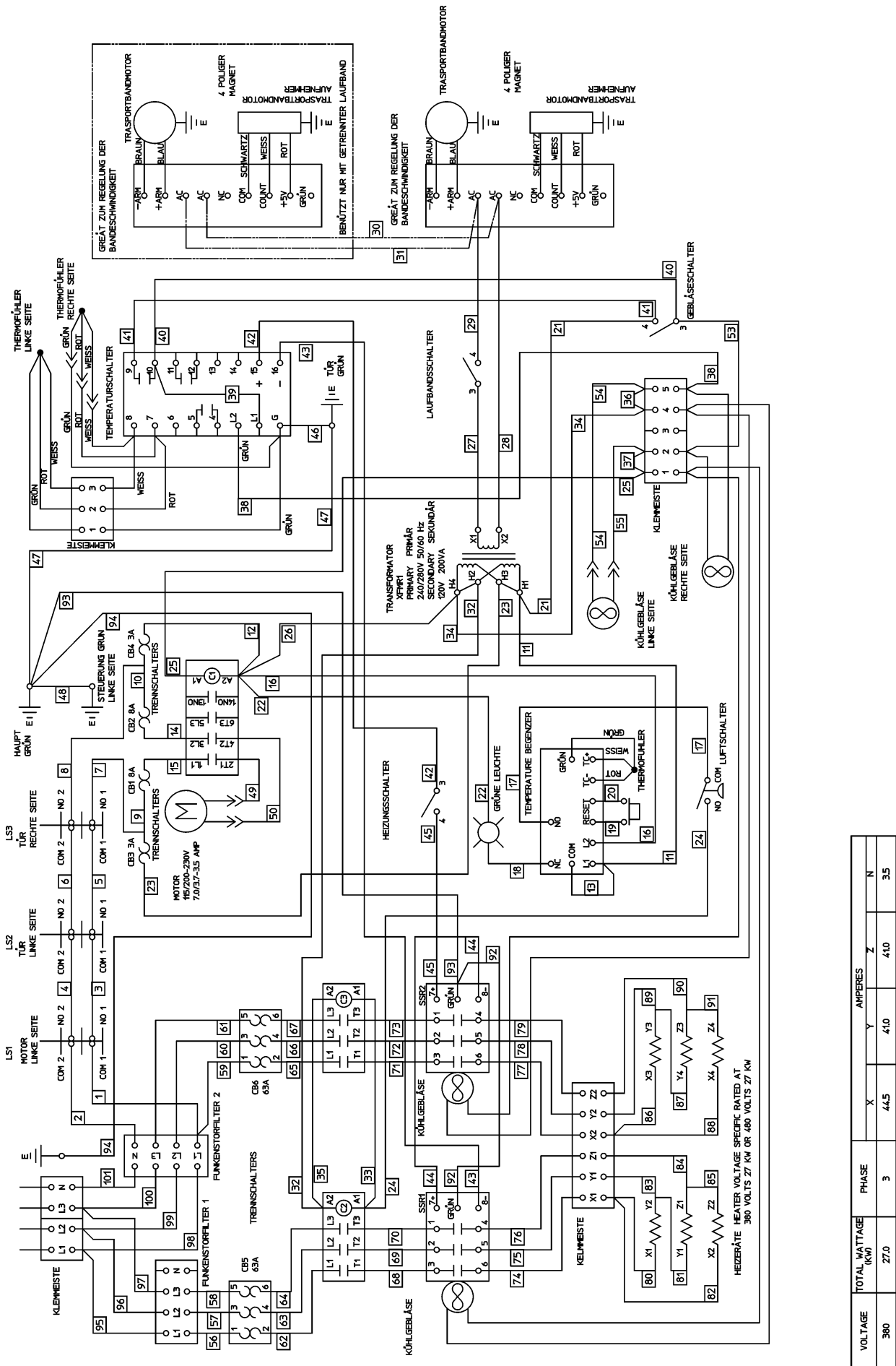

VOLTAGE	TOTAL WATTAGE (KW)	PHASE	X	Y	Z	N
380	27.0	3	44.5	41.0	41.0	3.5

Blodgett BE3240 Wiring Diagram, E380/50/60/3 5W CE 540 GM

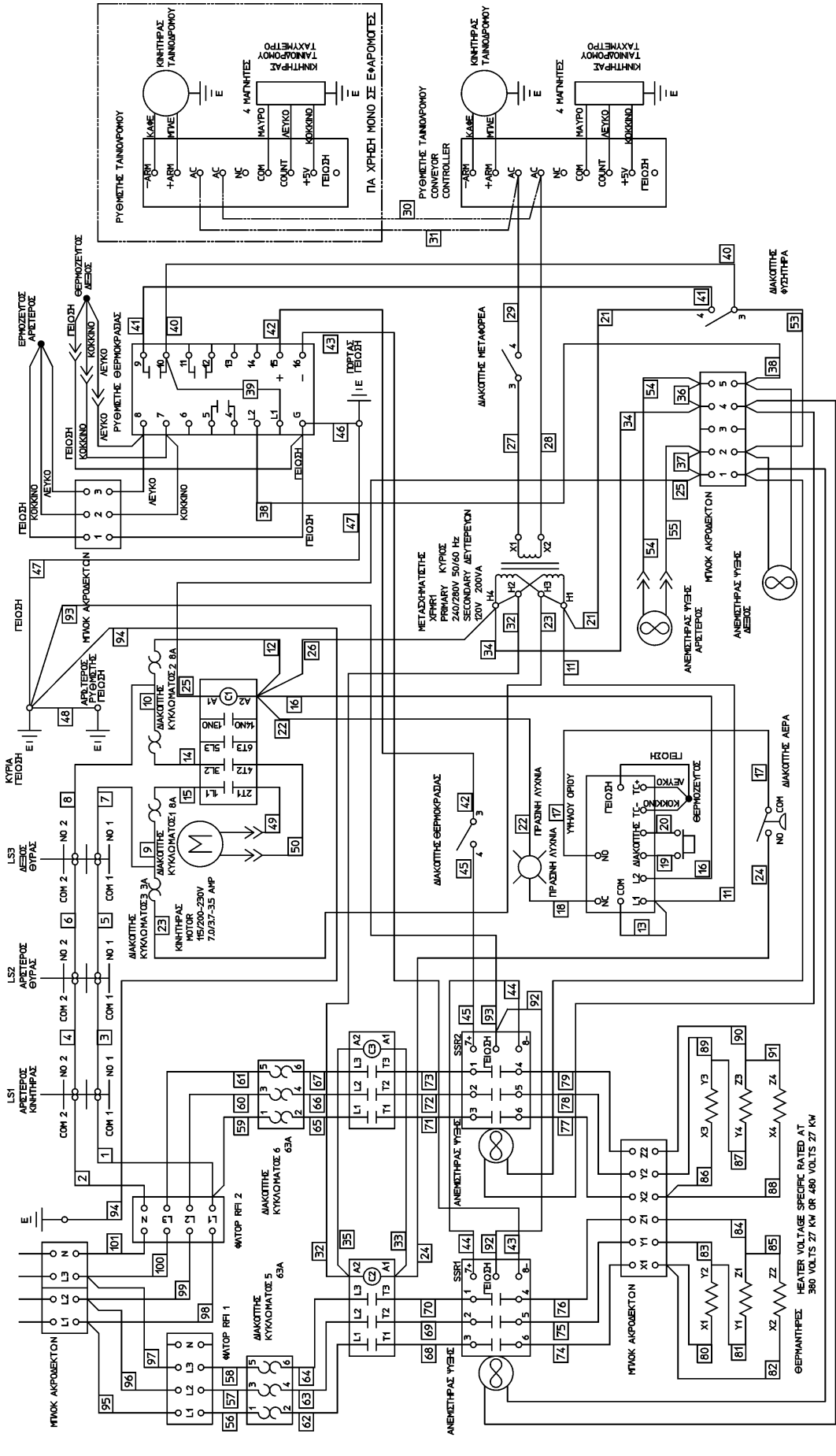

VOLTAGE	TOTAL WATTAGE (KW)	ΦASH	X	Y	Z	N
380	27.0	3	44.5	41.0	4.0	3.5

Blodgett BE3240 Wiring Diagram, E380/50/60/3 5W CE 540 GK

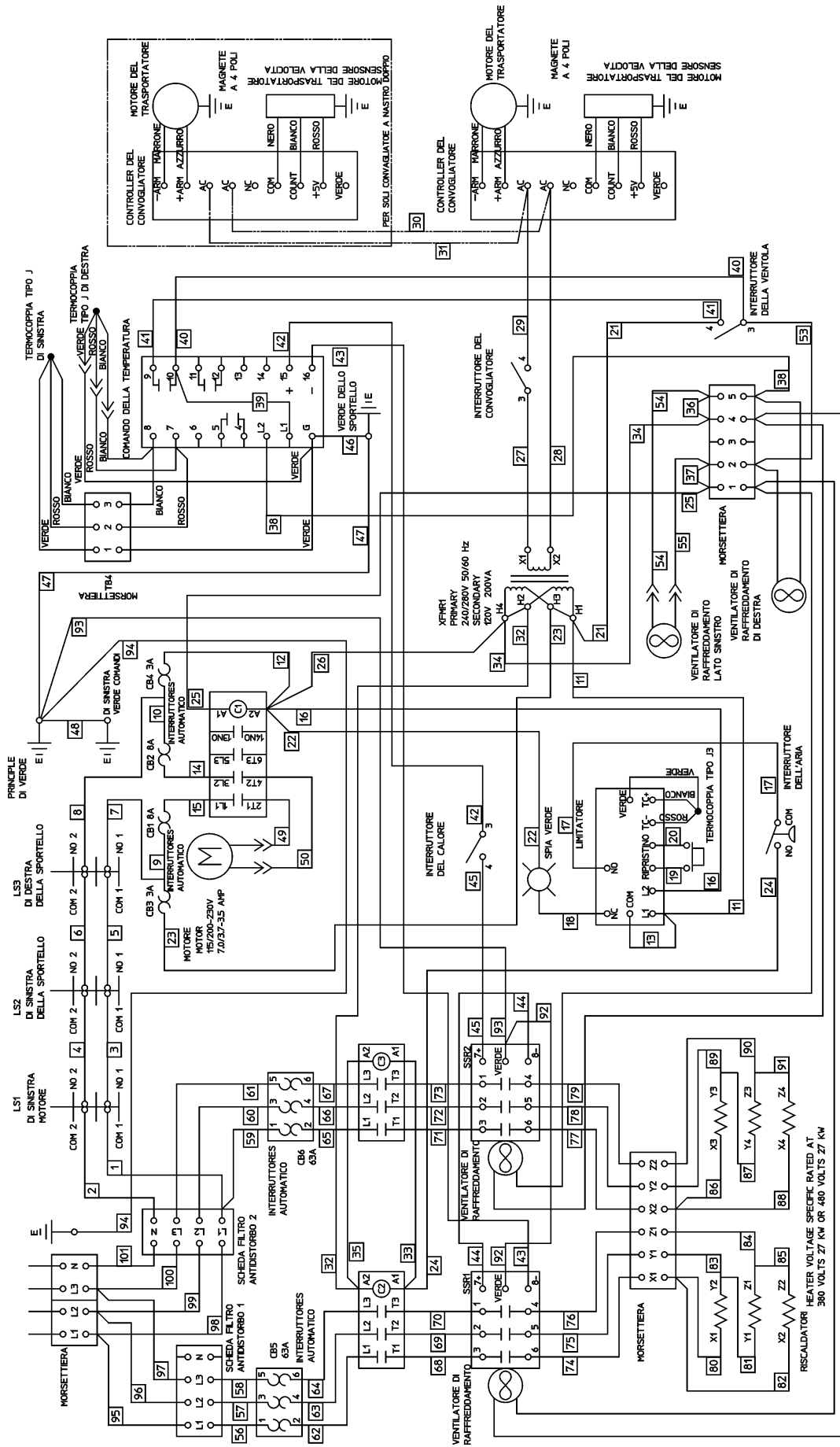

VOLTAGE	TOTAL WATTAGE (KW)	PHASE	AMPERES		
			X	Y	Z
380	27.0	3	44.5	41.0	41.0
					3.5

Blodgett BE3240 Wiring Diagram, E380/50/60/3 5W CE 540 IT

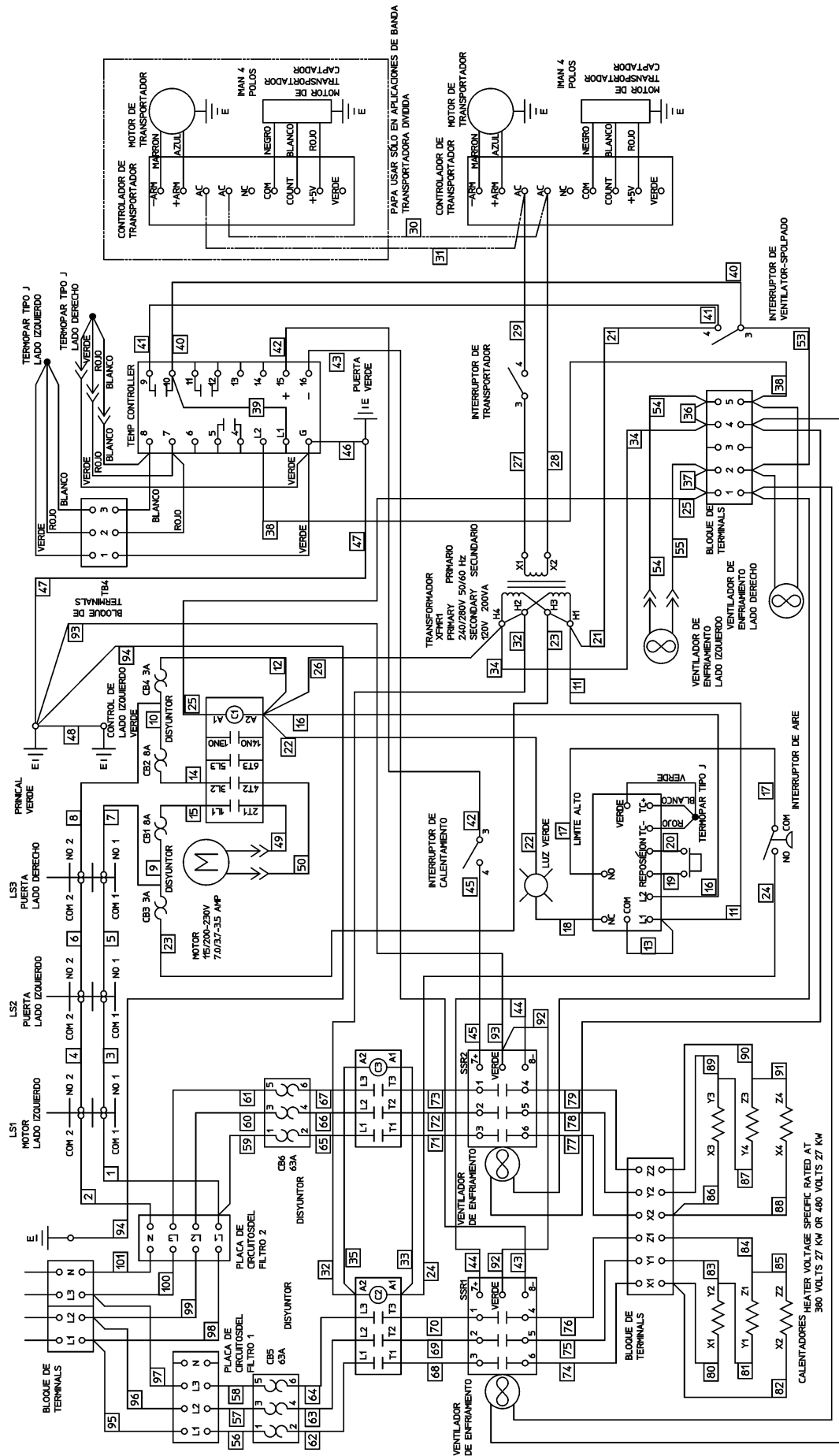

PARA USAR SÓLO EN APLICACIONES DE BANDA TRANSPORTADORA DIVIDIDA

51324 Rev. B

Blodgett BE3240 Wiring Diagram, E380/50/60/3 5W CE 540 SP

VOLTIOS	VAIOTOS (KW)			PHASE	AMPERIOS		
	X	Y	Z		X	Y	Z
380	27.0	44.5	41.0	3	41.0	41.0	3.5

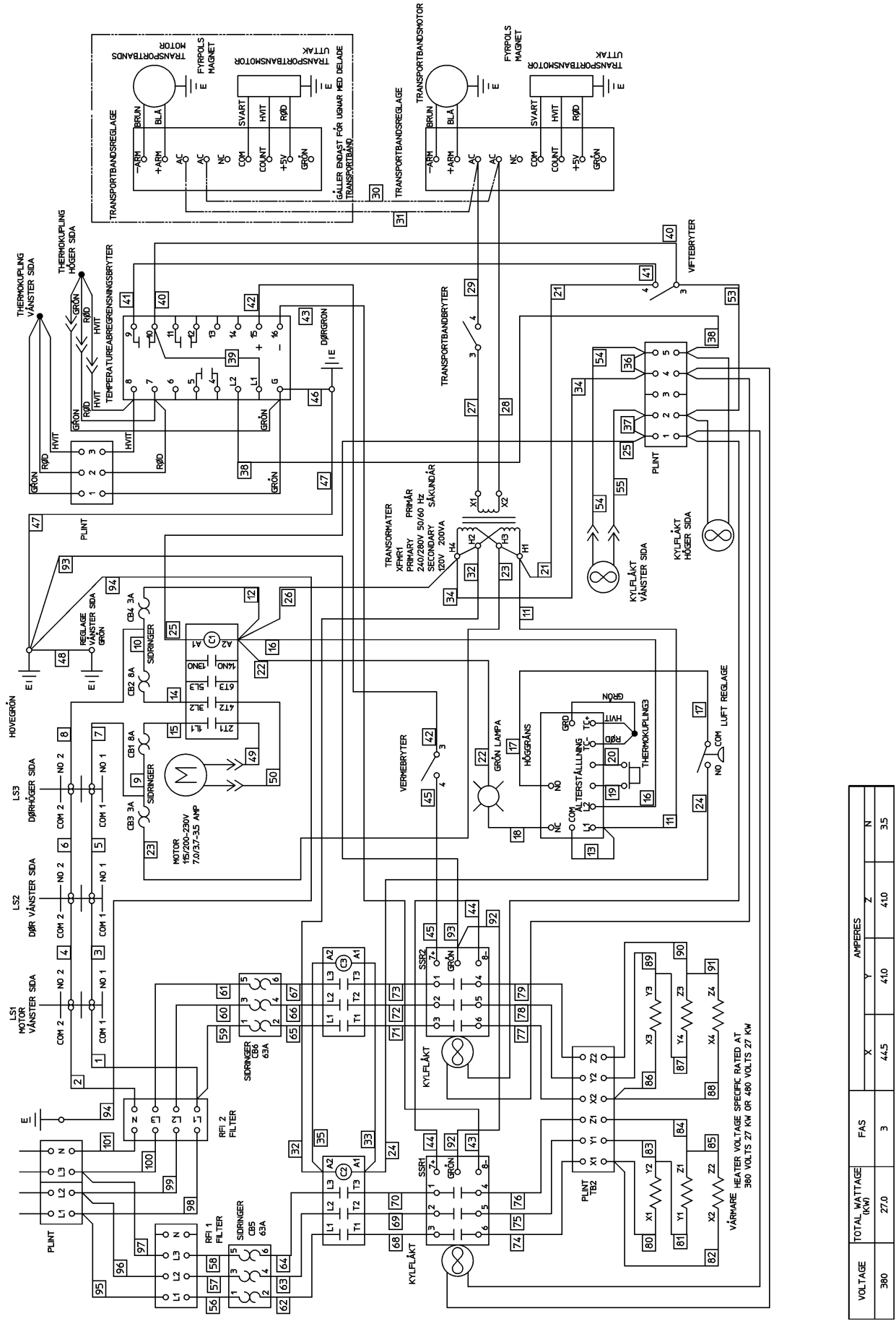

VOLTAGE	TOTAL WATTAGE (KW)	FAS				AMPERES			
		X	Y	Z	N	X	Y	Z	N
380	27.0	3	44.5	41.0	41.0	35			

